



EtherCAT[®]
Conformance tested
EM3E
Network Stepper Drive
Passed the conformance testing of ETG

Leadshine Technology Co., Ltd.

Website: www.leadshine.com

Service:

Tel: 86-755-2641-8774 (for Asia, Australia, Africa region)

86-755-8654-2465 (for Europe region)

86-755-2665-5136 (for America region)

86-755-2641-0546

Email: tech@leadshine.com

Sales Hot Line:

Tel: 86-755-2641-7674 (for Asia, Australia, Africa region)

86-755-2640-9254 (for Europe region)

86-755-2641-7617 (for America region)

Email: sales@leadshine.com



- ▶ Support CoE control and CiA 402 protocol
- ▶ Maximum communication rate of 100 Mbps
- ▶ Simplicity & High reliability
- ▶ Excellent performance
- ▶ 60% lower cost than EtherCAT servo

EM3E Series

These newly released EM3E series drives support CANopen over EtherCAT (CoE) control and CiA 402 operating modes including Profile Position (PP), Profile Velocity (PV), Homing(HM), Cyclic Synchronous Position (CSP). The products can be matched with most of EtherCAT controller/PLC such as Leadshine, Beckhoff, Omron, etc. The EM3E series has excellent performance including enhanced reliability, super-low stepper noise, anti-resonance, low-speed ripple smoothing and remains 60% less cost than EtherCAT servo at least.



EM3E Series Advantages

No.1 stepper products manufacturer in terms of shipment volume globally nowadays.

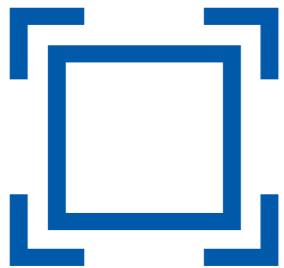

- High Reliability:**
 Successfully passed the conformance testing of the ETG, and applied in rich applications since released in 2016.
- Enhanced Communication Rate:**
 Maximum rate of 100Mbps to ensure real-time control in automation environments.
- Excellent performance:**
 Adopt Leadshine mature DSP control technology which enables super-low noise, anti-resonance, low-speed ripple smoothing, etc.

Customer Benefits



- Significantly reduced equipment cost:**
 At least lower 60% cost to replace EtherCAT servo when the required speed of applications under 1500 RPM.
- Significantly reduced potential cost:**
 Lower labor cost, lower cable cost and maintenance cost.
- Real-time data transfer:**
 Online monitoring of the status of motor and drive.

EM3E Series

EtherCAT System Connection Topology

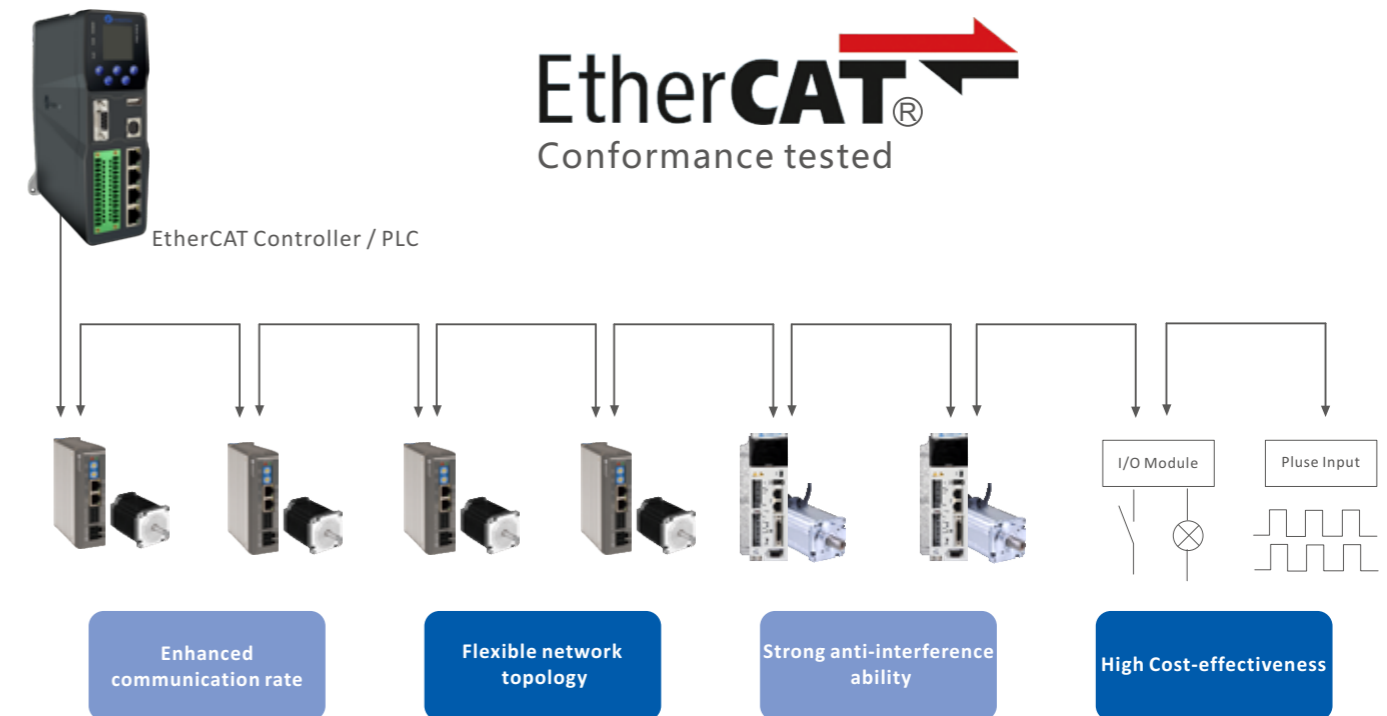

Contents

1. EM3E Series Overview
2. EM3E Series Drives
3. Matching Stepper Motor
4. Cables and Power Supplies
5. Ordering Information

01 EM3E Series Overview

1.1 Overview

| | Item | Description |
|-------------------------|---------------------------------|--|
| EtherCAT Specifications | Communication protocol standard | CoE (CANopen over EtherCAT) |
| | Equipment protocol standard | IEC61800-7 CiA 402 Drive Profile |
| | Control Modes | CSP (Cyclic Synchronous Position) PP(Profile Position) PV(Profile Velocity) HM(Homing) |
| | Synchronization Modes | DC Synchronization and Free-run mode |
| | Synchronization cycle | 250us,500us,750us, 1ms, 2ms, 4ms |
| General Specifications | Operating Voltage | 20 - 80VDC |
| | Bus Address Setting | Two 16-bit Rotary Switches |
| | Digital Input | EM3E-522/556/870: 5 input signals, include 4 single-ended and 1 differential connections; EM3E-A882: 7 input signals, include 5 single-ended and 2 differential connections Single-ended input voltage is 12-24V, 20KHz maximum Differential input voltage is 3.3-5V, 200/500 KHz maximum |
| | Digital Output | EM3E-522/556/870: 2 output signals, include alarm and brake; EM3E-A882: 6 output signals, include alarm and brake, etc. Optically isolated, 24V/100mA maximum |
| | Alarm Output | Over voltage, over current, etc. |

1.2 Typical Applications

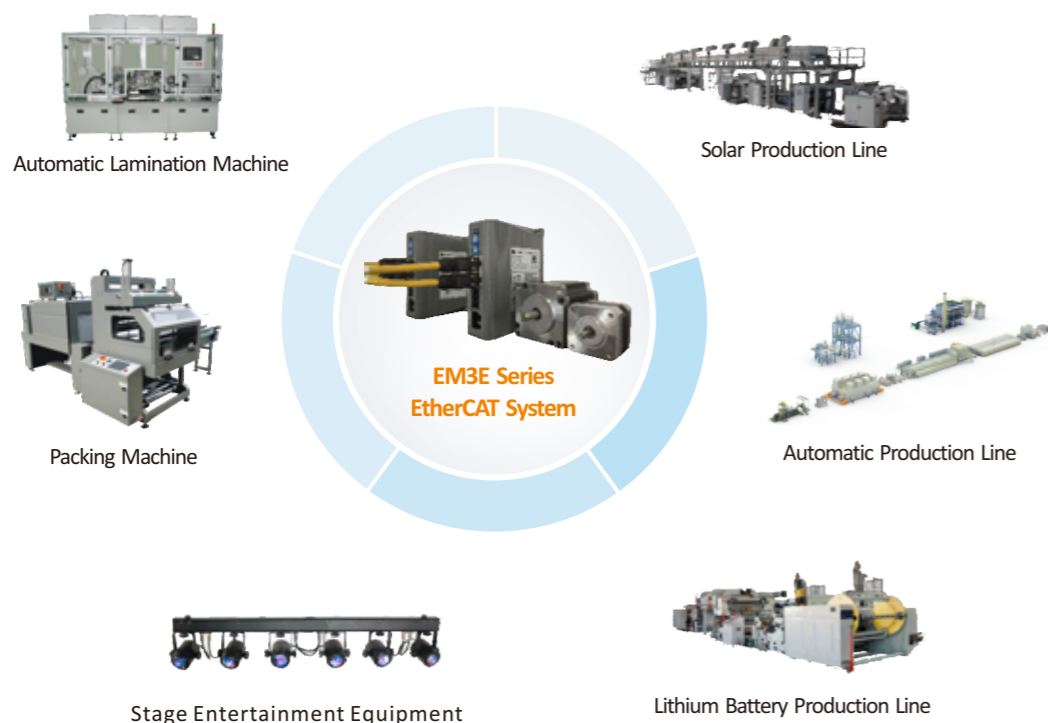

1.3 Features

1. Low-speed Ripple Smoothing

Electronic damping for 3 major resonance frequencies for stepper motors at low speed range, eliminating undesirable motor speed oscillation and delivering unique level of smoothness.

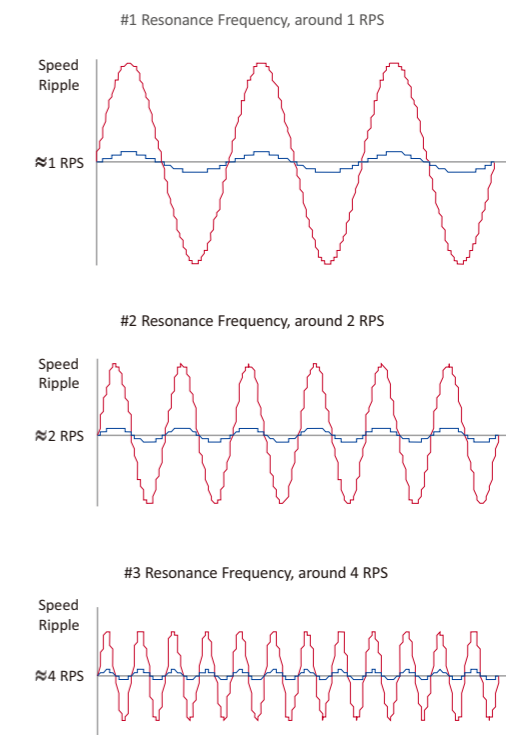

2. Command Signal Smoothing

Command signal smoothing can soften the effect of sudden changes in velocity and direction, thus delivering smoother performance and improving system lifetime.

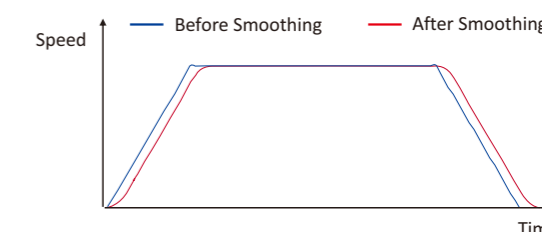

3. Alarm Output

Using alarm indicator and output signal feedback failure such as over-voltage or over-current timely to ensure the safety and reliability of equipment operation.



02 EM3E Series Drives

2.1 Part Number

EM3 - 5 56

 ① ② - ③ ④ ⑤ ⑥

① Series Name:
EM3: EM3 Series

② Communication Modes:
E: EtherCAT





③ DC or AC Power Input:
Blank: DC Input
A: AC or DC Input Optional

④ Operating Voltage:
5: Max 50V
8: Max 80V

⑤ Max Output Current:
56: 5.6A

⑥ Custom Models:

2.2 Electrical Specifications

| EtherCAT Network Stepper Drives | | | | |
|---------------------------------|---|---|--|---|
| Models |  |  |  |  |
| | EM3E-522 | EM3E-556 | EM3E-870 | EM3E-A882 |
| Operating Voltage | 20-50VDC | 20-50VDC | 20-80VDC | 20-80VAC or 30-110 VDC |
| Output Current | 0.3-2.2A(RMS 1.6A) | 1.0-5.6A(RMS 4A) | 2.1-7.0A(RMS 5A) | 3.2-8.2A(RMS 6A) |
| Matched Motor | NEMA 8,11,14,17 | NEMA 23,24 | NEMA 23,24,34 | NEMA 34 |

1 DC Power Input

| Models | Operating Voltage (VDC) | | | Output Peak Current ^① (A) | | Control Signal Current (mA) | | Control Signal Voltage ^② (VDC) | Over Voltage Point (VDC) |
|-----------|-------------------------|---------|-----|--------------------------------------|-----|-----------------------------|-----|---|--------------------------|
| | Min | Typical | Max | Min | Max | Min | Max | | |
| EM3E-522 | 20 | 24 | 50 | 0.5 | 2.2 | 7 | 16 | 5 - 24 | 90 |
| EM3E-556 | 20 | 24, 36 | 50 | 2.1 | 5.6 | 7 | 16 | 5 - 24 | 90 |
| EM3E-870 | 20 | 48,70 | 80 | 2.1 | 7.0 | 7 | 16 | 5 - 24 | 113 |
| EM3E-A882 | 20 | 90 | 110 | 3.2 | 8.2 | 7 | 16 | 5 - 24 | 160 |

Note: ① The minimum output current is default value, can be set to 0.1A via PC software;
② No additional resistance for 5V, 12V, 24V normally, while recommended to connect 1KΩ or 2KΩ resistance when using 12V or 24V in strong interference condition.

2.3 Typical Configuration

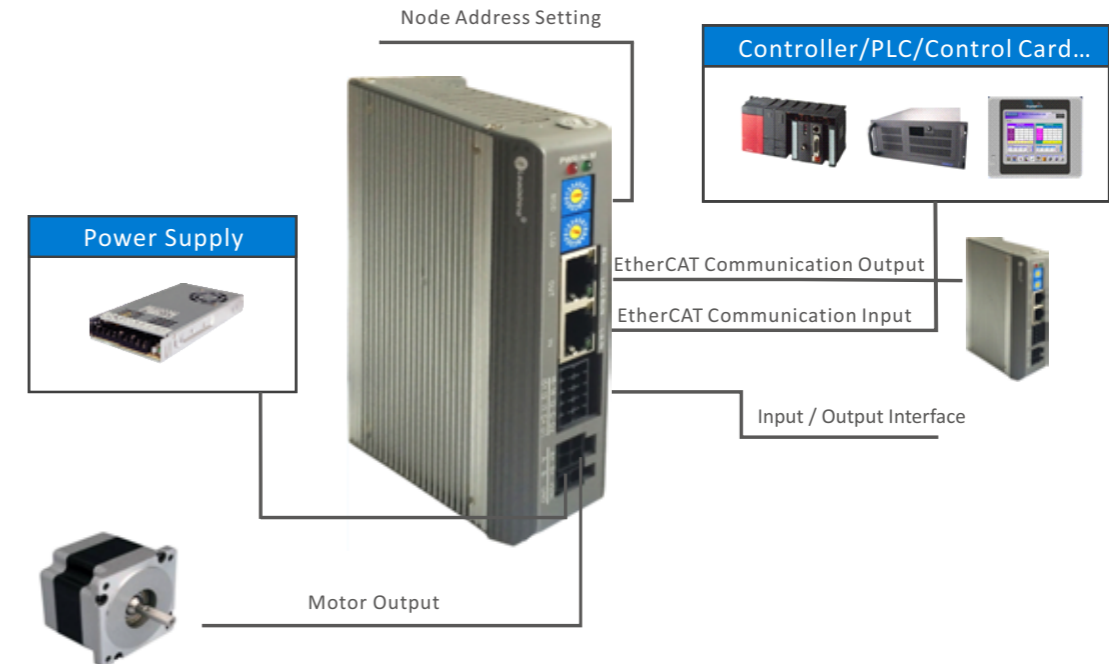

2.4 Connector Description

EM3E-522/556/870 Connector Description

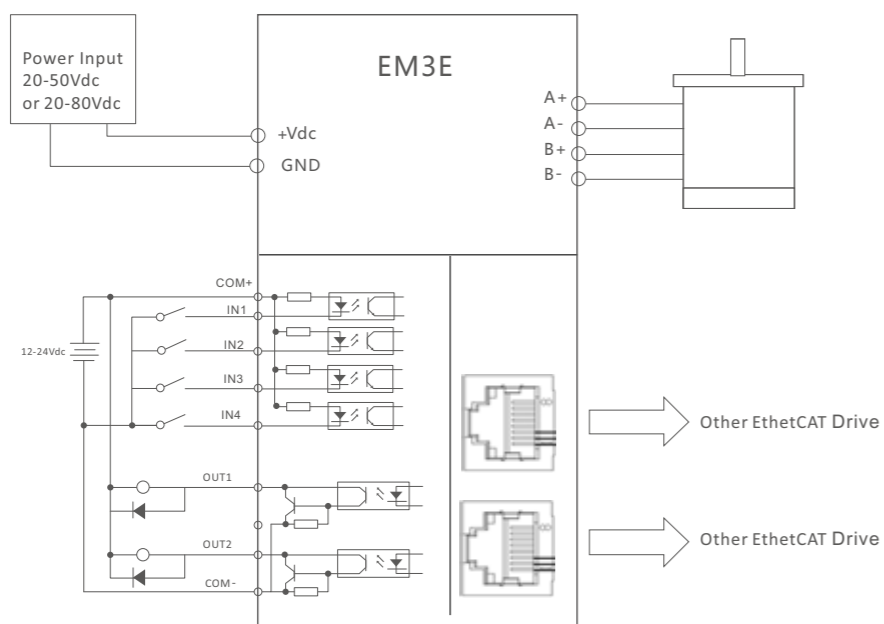

2.5 Mechanical Specifications

Unit: mm 1inch=25.4mm

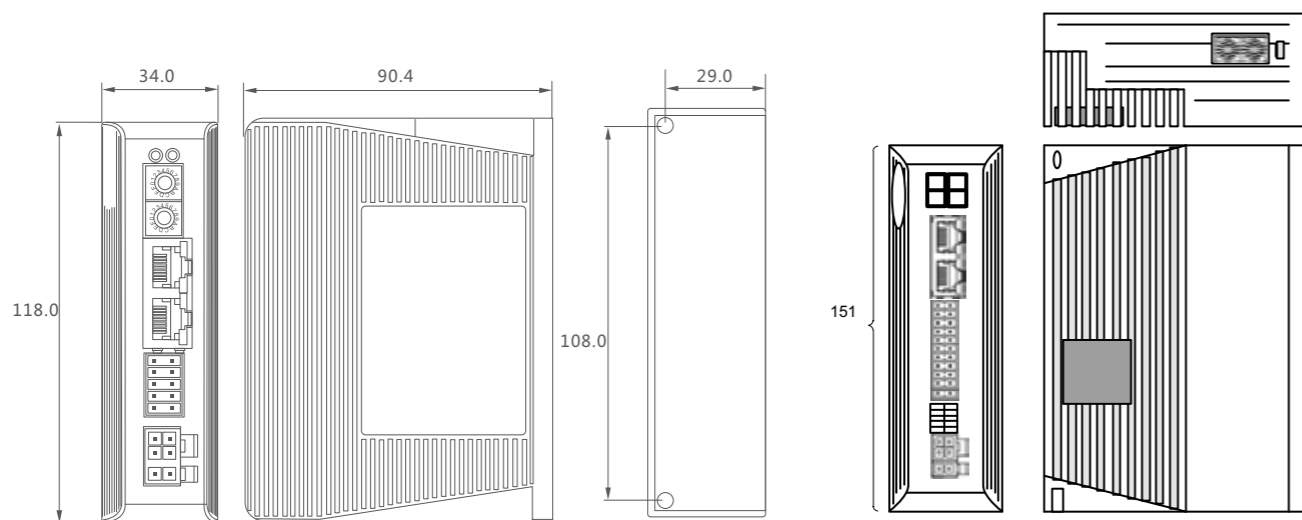

EM3E-522/556/870

EM3E-A882

03 Matching Stepper Motor — CM Series

3.1 Part Number

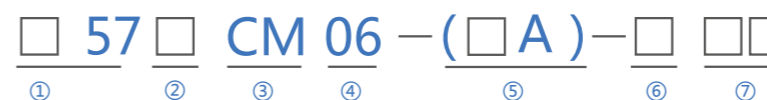

- ① **Motor Frame Size**
 20: NEMA 8 motor
 28: NEMA 11 motor
 35: NEMA 14 motor
 42: NEMA 17 motor
 57: NEMA 23 motor
 D57: NEMA 23 motor with larger body
 60: NEMA 24 motor
 86: NEMA 34 motor
- ② **Motor Phase**
 Blank: 2 phase motor
 3 : 3 phase motor
- ④ **Holding Torque**
 For NEMA 8/11/14 motor:
 Divide the value by 100
 015 : 0.15N.m
 For NEMA 17/23/24/34 motor:
 Divide the value by 10
 06: 0.6N.m
- ⑤ **Motor Rate Current**
 Blank: Standard rate current
 4A : Rate current 4A
- ⑥ **Standard Customized Specification**
 SZ : Double shaft motor
 BZ : Brake motor
 FS : Waterproof motor
- ⑦ **Customized model**

3.2 Models

| Motor Size | Model | Holding Torque (N.m) | Standard Type Length (mm) | Rate Current (A) | Matched EtherCAT Drive |
|------------|---------|----------------------|---------------------------|------------------|------------------------|
| NEMA 8 | 20CM003 | 0.03 | 33 | 0.6 | EM3E-522 |
| | 20CM005 | 0.05 | 45 | 0.6 | EM3E-522 |
| NEMA 11 | 28CM006 | 0.06 | 32 | 1.2 | EM3E-522 |
| | 28CM010 | 0.10 | 41 | 1.2 | EM3E-522 |
| | 28CM013 | 0.13 | 51 | 1.2 | EM3E-522 |
| NEMA 14 | 35CM015 | 0.15 | 31 | 2.0 | EM3E-522 |
| | 35CM04 | 0.36 | 47 | 2.0 | EM3E-522 |
| NEMA 17 | 42CM02 | 0.2 | 33 | 1.5 | EM3E-522 |
| | 42CM04 | 0.4 | 40 | 1.5 | EM3E-522 |
| | 42CM06 | 0.6 | 47 | 2.5 | EM3E-522/EM3E-556 |
| | 42CM08 | 0.8 | 60 | 2.5 | EM3E-522/EM3E-556 |

| Motor Size | Model | Holding Torque (N.m) | Standard Type Length(mm) | Rate Current (A) | Matched EetherCAT Drive |
|------------|------------|----------------------|--------------------------|------------------|-------------------------|
| NEMA 23 | 57CM06 | 0.6 | 41 | 3 | EM3E-556 |
| | 57CM13 | 1.3 | 56 | 4 | EM3E-556 |
| | 57CM23 | 2.3 | 76 | 5 | EM3E-556/EM3E-870 |
| | 57CM23-4A | 2.3 | 76 | 4 | EM3E-556 |
| | 57CM26 | 2.6 | 84 | 5 | EM3E-556/EM3E-870 |
| | 57CM26-4A | 2.6 | 84 | 4 | EM3E-556 |
| | D57CM21-4A | 2.1 | 67 | 4 | EM3E-556 |
| | D57CM31-4A | 3.1 | 88 | 4 | EM3E-556 |
| | D57CM21 | 2.1 | 67 | 5 | EM3E-556/EM3E-870 |
| | D57CM31 | 3.1 | 88 | 5 | EM3E-556/EM3E-870 |
| NEMA 24 | 60CM22X | 2.2 | 67 | 5 | EM3E-556/EM3E-870 |
| | 60CM30X | 3.0 | 85 | 5 | EM3E-556/EM3E-870 |
| NEMA 34 | 86CM35 | 3.5 | 66 | 4 | EM3E-556/EM3E-870 |
| | 86CM45 | 4.5 | 80 | 6 | EM3E-A882 |
| | 86CM80 | 8.0 | 98 | 6 | EM3E-A882 |
| | 86CM85 | 8.5 | 118 | 6 | EM3E-A882 |
| | 86CM120 | 12 | 129 | 6 | EM3E-A882 |

■ NEMA23

| Model | Standard Type Length(mm) | Holding Torque (N.m) | Rate Current (A) | Resistance/Phase(Ω) | Inductance /Phase (mH) | Inertia (Kg.cm ²) |
|--------|--------------------------|----------------------|------------------|---------------------|------------------------|-------------------------------|
| 57CM06 | 41 | 0.6 | 3 | 0.7 | 1.4 | 0.12 |
| 57CM13 | 56 | 1.3 | 4 | 0.42 | 1.4 | 0.3 |
| 57CM23 | 76 | 2.3 | 5 | 0.38 | 1.75 | 0.48 |
| 57CM26 | 84 | 2.6 | 5 | 0.44 | 2.0 | 0.52 |

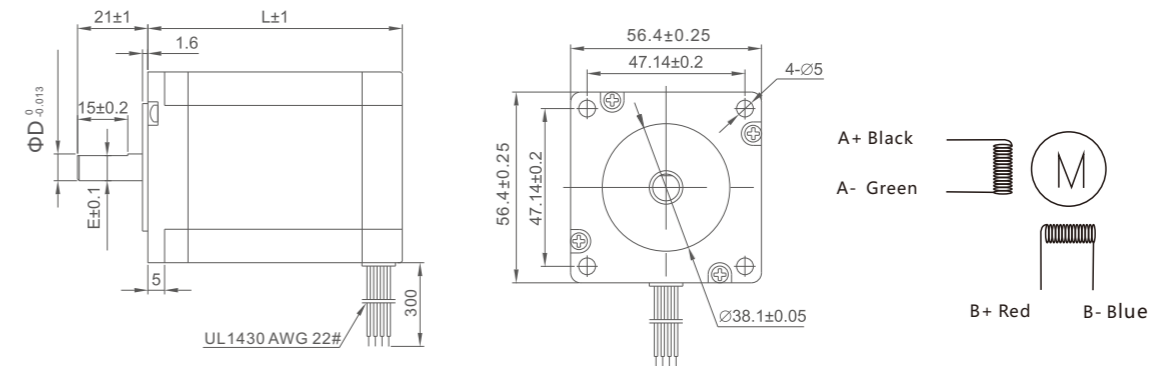

| Model | L (mm) | D (mm) | E (mm) |
|--------|--------|--------|--------|
| 57CM06 | 41 | 6.35 | 5.8 |
| 57CM13 | 56 | 6.35 | 5.8 |
| 57CM23 | 76 | 8 | 7.5 |
| 57CM26 | 84 | 8 | 7.5 |

■ NEMA23(Continous)

| Model | Standard Type Length(mm) | Holding Torque (N.m) | Rate Current (A) | Resistance/Phase(Ω) | Inductance /Phase (mH) | Inertia (Kg.cm ²) |
|---------|--------------------------|----------------------|------------------|---------------------|------------------------|-------------------------------|
| D57CM21 | 67 | 2.1 | 4 or 5 | 0.21 | 0.75 | 0.57 |
| D57CM31 | 88 | 3.1 | 4 or 5 | 0.26 | 1.18 | 0.84 |

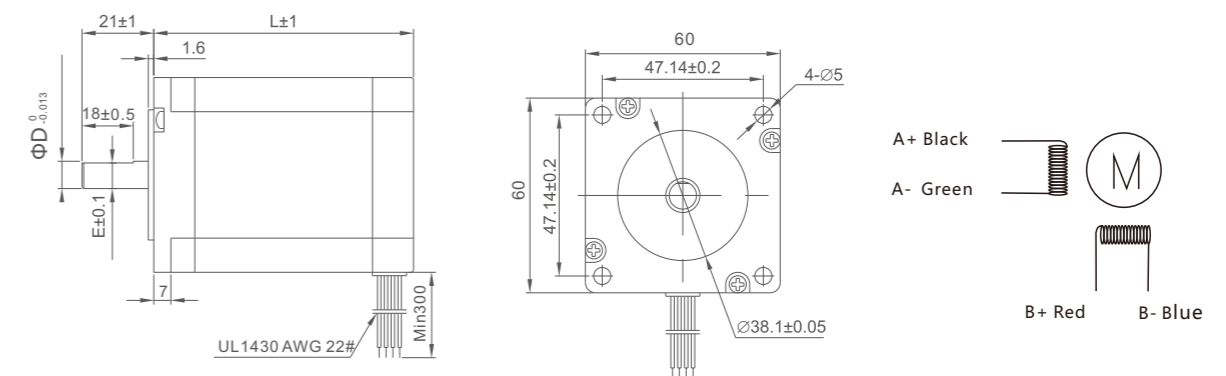

| Model | L (mm) | D (mm) | E (mm) |
|---------|--------|--------|--------|
| D57CM21 | 67 | 8 | 7.5 |
| D57CM31 | 88 | 8 | 7.5 |

3.3 Motor Specifications

Unit: mm 1 inch=25.4mm

■ NEMA17

| Model | Standard Type Length(mm) | Holding Torque (N.m) | Rate Current (A) | Resistance/Phase(Ω) | Inductance /Phase (mH) | Inertia (Kg.cm ²) |
|--------|--------------------------|----------------------|------------------|---------------------|------------------------|-------------------------------|
| 42CM02 | 33 | 0.2 | 1.5 | 1.4 | 1.4 | 0.035 |
| 42CM04 | 39 | 0.4 | 1.5 | 2.4 | 4.3 | 0.054 |
| 42CM06 | 47 | 0.6 | 2.5 | 0.9 | 1.6 | 0.072 |
| 42CM08 | 60 | 0.8 | 2.5 | 1.0 | 2.4 | 0.11 |

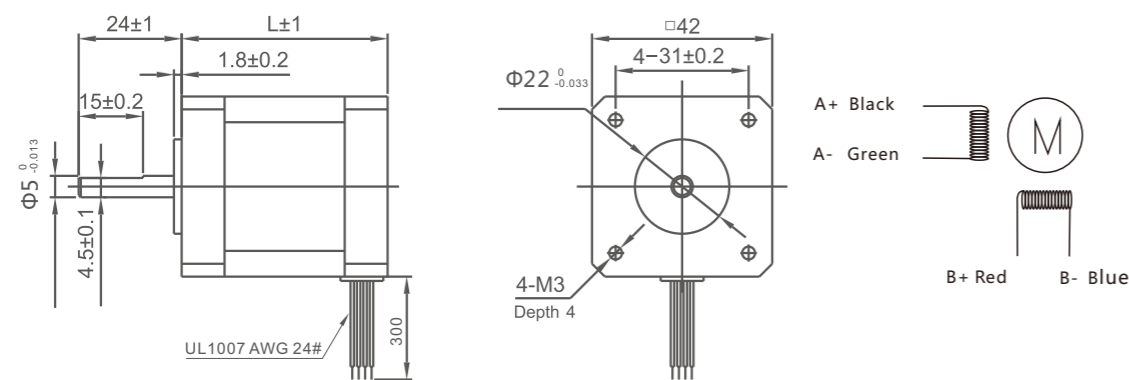

Note:
 ① Contact Leadshine for datasheet of NEMA 8/11/14 stepper motors.
 ② Contact Leadshine for special type motor such as brake, double shaft, waterproof, etc.

NEMA24

| Model | Standard Type Length(mm) | Holding Torque (N.m) | Rate Current (A) | Resistance/Phase(Ω) | Inductance /Phase (mH) | Inertia (Kg.cm ²) |
|---------|--------------------------|----------------------|------------------|------------------------------|------------------------|-------------------------------|
| 60CM22X | 67 | 2.2 | 5 | 0.33 | 1.05 | 0.49 |
| 60CM30X | 85 | 3.0 | 5 | 0.46 | 2.0 | 0.69 |

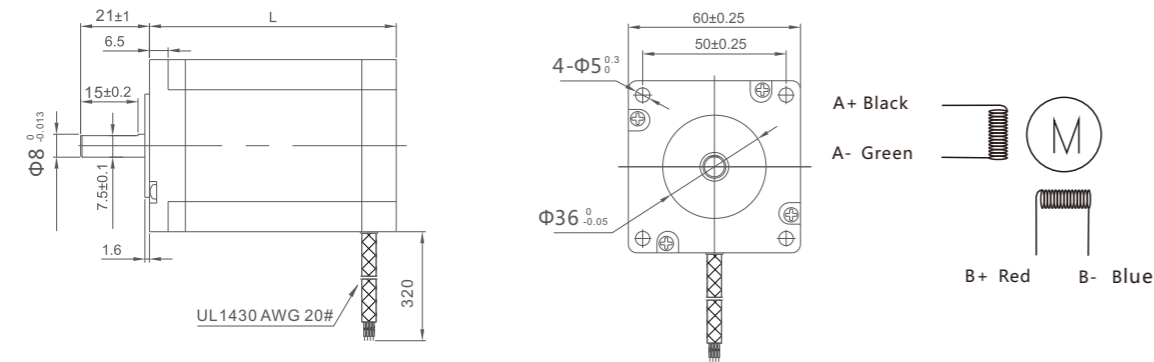

NEMA34

| Model | Standard Type Length(mm) | Holding Torque (N.m) | Rate Current (A) | Resistance/Phase(Ω) | Inductance /Phase (mH) | Inertia (Kg.cm ²) |
|--------|--------------------------|----------------------|------------------|------------------------------|------------------------|-------------------------------|
| 86CM35 | 66 | 3.5 | 4 | 0.42 | 2.67 | 1.0 |
| 86CM45 | 80 | 4.5 | 6 | 0.43 | 2.95 | 1.4 |
| 86CM80 | 98 | 8.0 | 6 | 0.63 | 4.0 | 2.5 |
| 86CM85 | 118 | 8.5 | 6 | 0.53 | 4.25 | 2.7 |

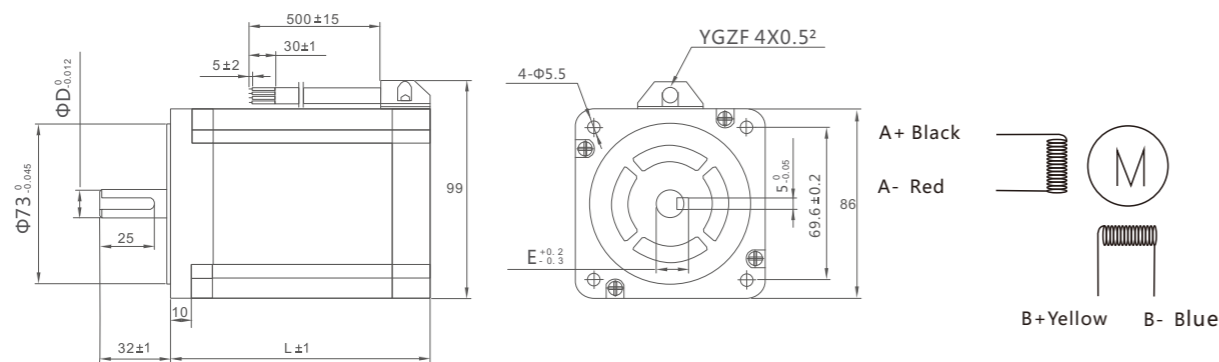

| Model | L (mm) | D (mm) | E (mm) |
|--------|--------|--------|--------|
| 86CM35 | 66 | 12.7 | 14.7 |
| 86CM45 | 80 | 12.7 | 14.7 |
| 86CM80 | 98 | 12.7 | 14.7 |
| 86CM85 | 118 | 12.7 | 14.7 |

Note:
 ① Contact Leadshine for datasheet of NEMA 8/11/14 stepper motors.
 ② Contact Leadshine for special type motor such as brake, double shaft, waterproof, etc.

04 Cables and Power Supplies

4.1 Power Supplies

1 SPS Series Power Supplies

Features

- Specially Designed Power Supplies for Stepper and Servo Controls
- Compact Size, Light in Weight
- Wide Input Voltage Range, 220VAC ± 10% or 110 VAC ± 10%
- Shortcut, Over-current, Over-voltage, Low-voltage Protections
- Big Power with High Efficiency
- Easy to Use



Electrical Specifications

| Model | Output Voltage (VDC) | Continuous Current (A) | Peak Current (A) | Input Voltage | Matching Drives | Dimensions | Weight(Kg) |
|---------------|----------------------|------------------------|------------------|------------------------------------|------------------------|--------------|------------|
| SPS2410(V3.0) | 24 | 10 | 30 | 220VAC± 10% or 110 VAC ± 10% | EM3E-522/ EM3E-556 | 199*110*50mm | 0.8 |
| SPS3611(V3.0) | 36 | 11 | 33 | | | 215*110*30mm | 0.6 |
| SPS488(V3.0) | 48 | 8.3 | 24.9 | | | 215*110*30mm | 0.6 |
| SPS4810(V3.0) | 48 | 10 | 30 | | 215*110*50mm | 0.8 | |
| SPS606(V3.0) | 60 | 6.7 | 20.1 | | EM3E-870/ EM3E-A882 | 215*110*30mm | 0.6 |

Mechanical Specifications

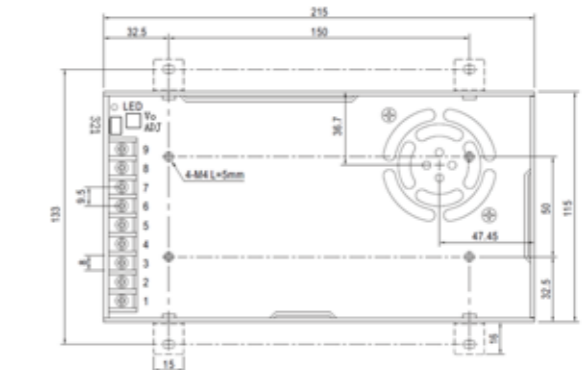
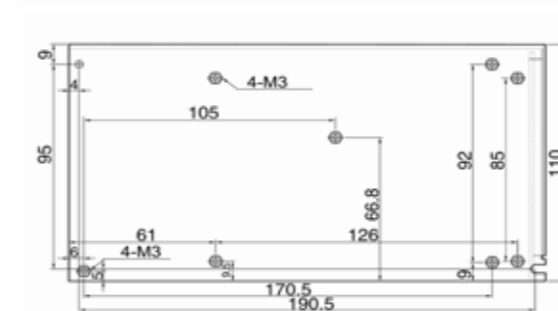
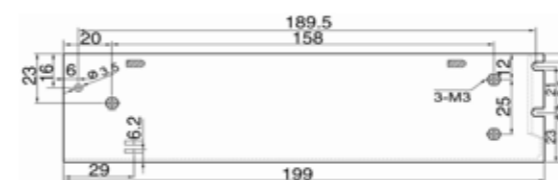

SPS2410(V3.0)

SPS3611(V3.0)/SPS488(V3.0)/SPS606(V3.0) H=30mm
 SPS4810(V3.0) H=50mm

4.2 Cables

1 Cables for Communication

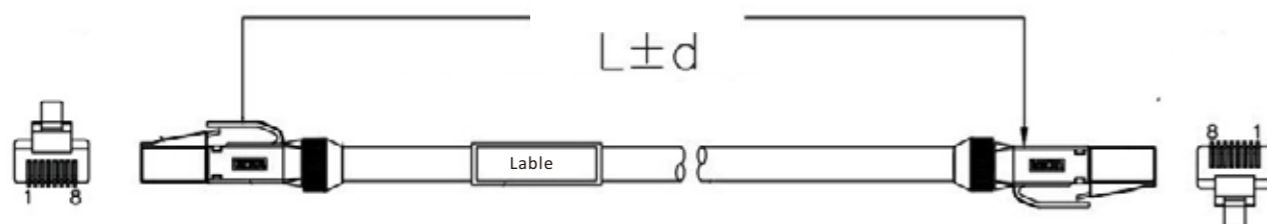

2 Specification

| Model | Length (L) | Tolerance (d) |
|-----------------------|------------|---------------|
| CABLE-TX0M1-BUS RoHS | 100mm | ±10mm |
| CABLE-TX0M2-BUS RoHS | 200mm | ±10mm |
| CABLE-TX0M3-BUS RoHS | 300mm | ±10mm |
| CABLE-TX0M5-BUS RoHS | 400mm | ±10mm |
| CABLE-TX1M0-BUS RoHS | 1000mm | ±10mm |
| CABLE-TX1M5-BUS RoHS | 1500mm | ±10mm |
| CABLE-TX2M0-BUS RoHS | 2000mm | ±10mm |
| CABLE-TX3M0-BUS RoHS | 3000mm | ±10mm |
| CABLE-TX5M0-BUS RoHS | 5000mm | ±10mm |
| CABLE-TX7M0-BUS RoHS | 7000mm | ±10mm |
| CABLE-TX10M0-BUS RoHS | 10000mm | ±10mm |
| CABLE-TX15M0-BUS RoHS | 15000mm | ±10mm |
| CABLE-TX20M0-BUS RoHS | 20000mm | ±10mm |

05 Ordering Information

| EtherCAT Drive Model | Input Power Voltage | Output Peak Current | Matched Motor | Holding Torque (N.m) |
|----------------------|---------------------------------|---------------------|---------------|----------------------|
| EM3E-522 | 20 - 50 (VDC) | 0.5 - 2.2 (A) | 20CM003 | 0.03 |
| | | | 20CM005 | 0.05 |
| | | | 28CM006 | 0.06 |
| | | | 28CM010 | 0.10 |
| | | | 28CM013 | 0.13 |
| | | | 35CM015 | 0.15 |
| | | | 35CM04 | 0.36 |
| | | | 42CM02 | 0.2 |
| | | | 42CM04 | 0.4 |
| | | | 42CM06 | 0.6 |
| EM3E-556 | 20 - 50 (VDC) | 2.1 - 5.6 (A) | 42CM08 | 0.8 |
| | | | 57CM06 | 0.6 |
| | | | 57CM13 | 1.3 |
| | | | 57CM23 | 2.3 |
| | | | 57CM23-4A | 2.3 |
| | | | 57CM26 | 2.6 |
| | | | 57CM26-4A | 2.6 |
| | | | D57CM21-4A | 2.1 |
| | | | D57CM31-A4 | 3.1 |
| | | | D57CM21 | 2.1 |
| EM3E-870 | 20 - 80 (VDC) | 2.1 - 7.0 (A) | D57CM31 | 3.1 |
| | | | 60CM22X | 2.2 |
| | | | 60CM30X | 3.0 |
| | | | 86CM35 | 3.5 |
| EM3E-A882 | 20 - 80 (VAC) 30 - 110 (VDC) | 3.2 - 8.2 (A) | 86CM45 | 4.5 |
| | | | 86CM80 | 8.0 |
| | | | 86CM85 | 8.5 |
| | | | 86CM120 | 12 |
| Accessories | Cables of communication | | | |