

ES-D508 Easy Servo Drive

20-50VDC, 8.0A Peak, Closed-loop, No Tuning

- | Closed-loop, eliminates loss of synchronization
- | Broader operating range – higher torque and higher speed
- | Reduced motor heating and more efficient
- | Smooth motion and super-low motor noise
- | Do not need a high torque margin
- | No Tuning and always stable
- | Quick response, no delay and almost no settle time
- | High torque at starting and low speed, high stiffness at standstill
- | Offer servo-like performance at a much lower cost



Descriptions

Leadshine's Easy Servo Drive offers an alternative for applications requiring high performance and high reliability when the servo was the only choice, while it remains cost-effective. The system includes a stepper motor combined with a fully digital, high performance drive and an internal encoder which is used to close the position, velocity and current loops in real time, just like servo systems. It combines the best of servo and stepper motor technologies, and delivers unique capabilities and enhancements over both, while at a fraction of the cost of a servo system.

Applications

Its great feature of quick response and no hunting make Leadshine's Easy Servo Drive ideal for applications such as bonding and vision systems in which rapid motions with a short distance are required and hunting would be a problem. And it is ideal for applications where the equipment uses a belt-drive mechanism or otherwise has low rigidity and you don't want it to vibrate when stopping.

Specifications

Electrical Specifications

Parameter	Min	Typical	Max	Unit
Input Voltage	20	36	50	VDC
Output Current	0	-	8.0(Peak)	A
Pulse Input Frequency	0	-	200	kHz
Logic Signal Current	7	10	16	mA
Isolation Resistance	500	-	-	MΩ

Operating Environment

Cooling	Natural Cooling or Forced cooling	
Operating Environment	Environment	Avoid dust, oil fog and corrosive gases
	Storage Temperature	-20°C – 65°C (-4°F – 149°F)
	Ambient Temperature	0°C – 50°C (32°F – 122°F)
	Humidity	40%RH – 90%RH
	Operating Temperature (Heat Sink)	70°C (158°F) Max
Storage Temperature	-20°C – 65°C (-4°F – 149°F)	
Weight	280 g (9.9 oz)	

Mechanical Specifications

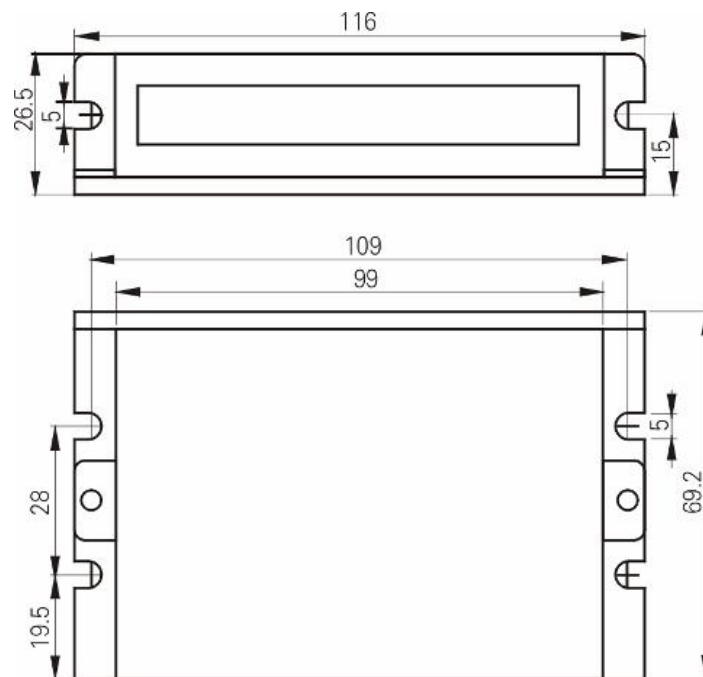

Protection Indications

The green indicator turns on when power-up. When drive protection is activated, the red LED blinks periodically to indicate the errors.

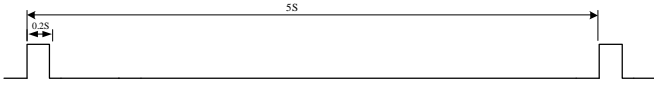
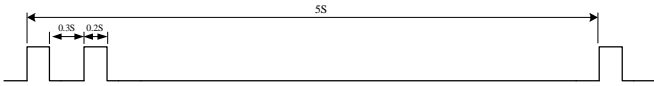
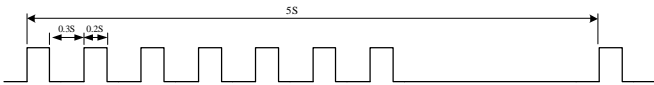
Priority	Time(s) of Blink	Sequence wave of RED LED	Description
1st	1		Over-current protection
2nd	2		Over-voltage protection
3rd	7		Position Following Error

Connectors and Pin Assignment

The ES-D508 has three connectors, connector for control signals connections, connector for encoder feedback and connector for power and motor connections.

Control Signal Connector - Screw Terminal			
Pin	Name	I/O	Description
1	PUL+	I	<u>Pulse signal</u> : In single pulse (pulse/direction) mode, this input represents pulse signal, each rising or falling edge active (software configurable, see easy servo software operational manual for more details); In double pulse mode (software configurable), this input represents clockwise (CW) pulse, active both at high level and low level. 4-5V when PUL-HIGH, 0-0.5V when PUL-LOW. For reliable response, pulse width should be longer than 2.5 μ s. Series connect resistors for current-limiting when +12V or +24V used. The same as DIR and ENA signals.
2	PUL-	I	
3	DIR+	I	<u>Direction Signal</u> : In single-pulse mode, this signal has low/high voltage levels, representing two directions of motor rotation. In double-pulse mode (software configurable), this signal is counter-clock (CCW) pulse, active both at high level and low level. For reliable motion response, DIR signal should be ahead of PUL signal by 5 μ s at least. 4-5V when DIR-HIGH, 0-0.5V when DIR-LOW. Toggle DIP switch SW1 to reverse motion direction.
4	DIR-	I	
5	ENA+	I	<u>Enable Signal</u> : This signal is used for enabling/disabling the driver. In default, high level (NPN control signal) for enabling the driver and low level for disabling the driver. Usually left UNCONNECTED (ENABLED). Please note that PNP and Differential control signals are on the contrary, namely low level for enabling. The active level of ENA signal is software configurable.
6	ENA-	I	

Connectors and Pin Assignment (Continued)

Control Signal Connector - Screw Terminal			
Pin	Name	I/O	Description
7	ALM+	O	Alarm Signal: OC output signal, active when one of the following protection is activated: over-voltage, over current, short circuit and position following error. This port can sink or source 20mA current at 24V. In default, the resistance between ALM+ and ALM- is low impedance in normal operation and become high when the ES-D508 goes into error. The active level of alarm signal is software configurable. See easy servo software operational manual for more details.
8	ALM-	O	

Encoder Feedback Connector – HDD15 Female			
Pin	Name	I/O	Description
1	EA+	I	Encoder channel A+ input
2	EB+	I	Encoder channel B+ input
3	EGD	GND	Signal ground
4	NC	I	Not Connected, Reserved for future use.
5	NC	I	Not Connected, Reserved for future use.
6	FG	-	Ground terminal for shielded
7	NC	I	Not Connected, Reserved for future use.
8	NC	I	Not Connected, Reserved for future use.
9	NC	I	Not Connected, Reserved for future use.
10	NC	-	Not Connected
11	EA-	I	Encoder channel A- input
12	EB-	I	Encoder channel B- input
13	VCC	O	+5V @ 100 mA max.
14	NC	-	Not Connected
15	NC	-	Not Connected

Power and Motor Connector- Screw Terminal			
Pin	Name	I/O	Description
1	U	O	Motor Phase U
2	V	O	Motor Phase V
3	W	O	Motor Phase W
4	+Vdc	I	Power Supply Input (Positive), 20-45VDC recommended, leaving rooms for voltage fluctuation and back-EMF.
5	GND	GND	Power Ground (Negative)

RS232 Communication Port

It is used to configure the peak current, microstep, active level, current loop parameters and anti-resonance parameters.

RS232 Communication Port – RJ11			
Pin	Name	I/O	Description
1	NC	-	Not connected.
2	+5V	O	+5V power output.
3	TxD	O	RS232 transmit.
4	GND	GND	Ground.
5	RxD	I	RS232 receive.
6	NC	-	Not connected.

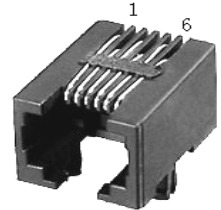

DIP Switch - Motor SEL

The SW1 can be used to change the motor direction. The SW2 is reserved for future use.

Current Control

The motor current will be adjusted automatically regarding to the load or the stator-rotor relationship. However, the user can also configure the current in the tuning software. The configurable parameters include close-loop current, holding current, encoder resolution, micro step and etc. There are also PID parameters for the current loop, and they have been tuned for Leadshine's matching motors so the user does not need to tune them.

Easy Servo Motors

The ES-D508 can work with the following easy servo motors from Leadshine:

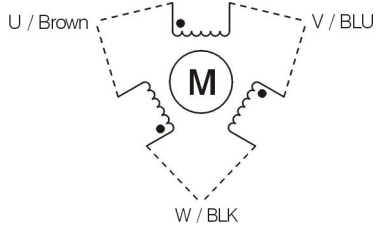
	ES-M32309(-S0605)	ES-M32320(-S0605)	Wiring Diagram
Step Angle (Degree)	1.2	1.2	
Holding Torque (N.m)	0.9	2.0	
Phase Current (A)	5.8	5.8	
Phase Resistance (Ohm)	0.37	0.62	
Phase Inductance (mH)	0.92	1.85	
Inertia (g.cm ²)	300	500	
Weight (Kg)	0.7	1.3	
Encoder (lines / Rev.)	1000	1000	

Motor Encoder Cable Pin-Out

ES-M32309(-S0605), ES-M32320(-S0605)

Pin	Name	Wire Color	I/O	Description
1	EA+	Black	O	Channel A+ output
2	EB+	Yellow	O	Channel B+ output
3	GND	White	GND	Ground
11	EA-	Blue	O	Channel A- output
12	EB-	Green	O	Channel B- output
13	VCC	Red	I	+5V power input

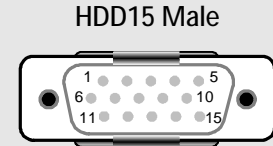

Typical Connections

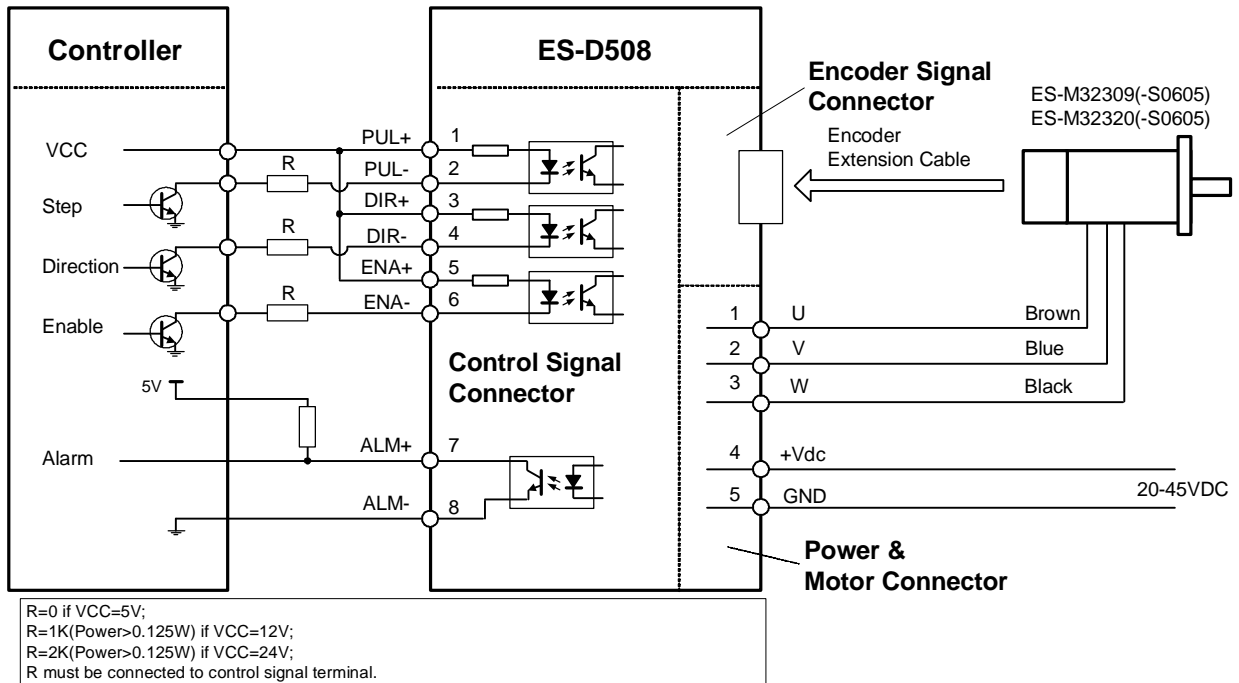

Connections to controller of sinking output

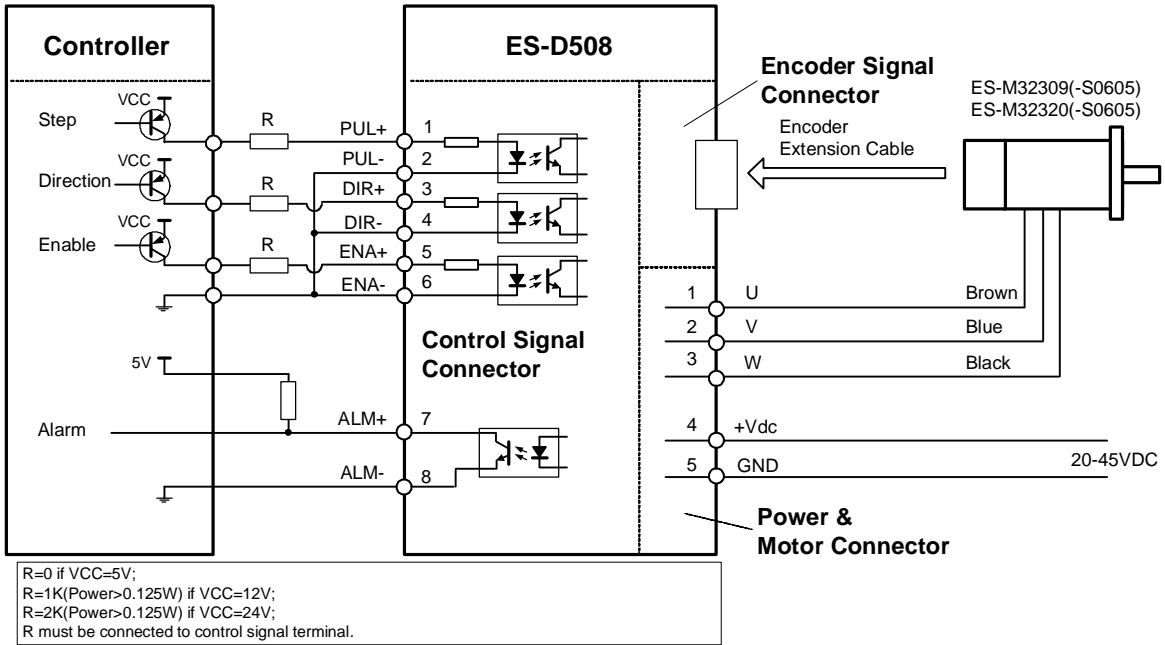
Typical Connections (Continued)

Connections to controller of sourcing output

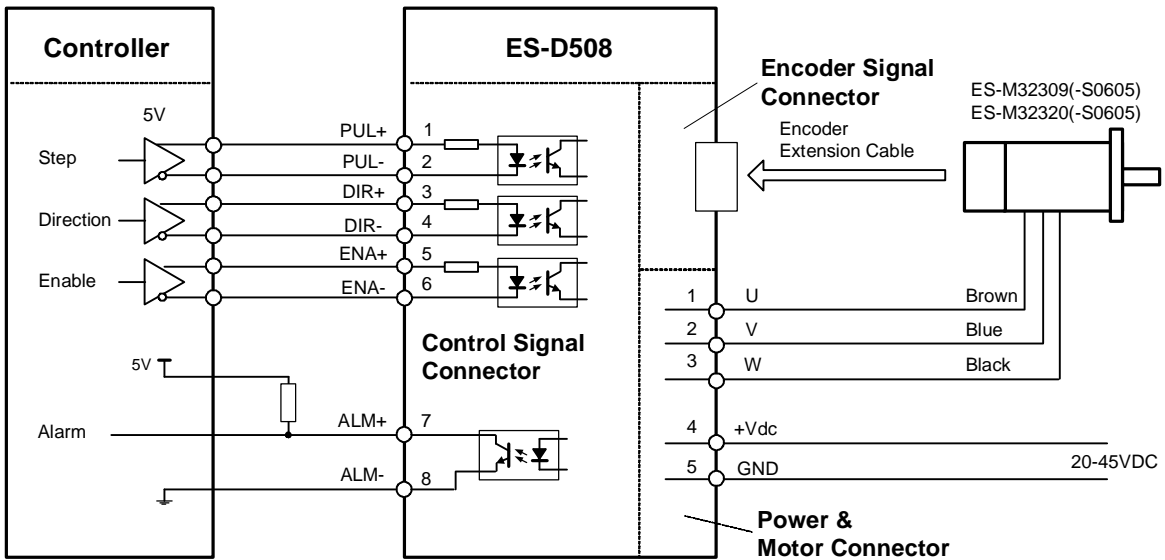

Connections to controller of differential output