



China Headquarters

Address: 3/F, Block 2, Nanyou Tianan Industrial Park, Nanshan District Shenzhen, China
Website: <http://www.leadshine.com>

Sales Hot Line:

Tel: 86-755-2641-7674 (for Asia, Australia, Africa region)
86-755-2640-9254 (for Europe region)
86-755-2641-7684 (for America region)
Fax: 86-755-2640-2718
Email: sales@leadshine.com

Technical Support:

Tel: 86-755-2641-8447 and 86-755-2647-1129
Fax: 86-755-2640-2718
Email: tech@leadshine.com and vic@leadshine.com

Leadshine U.S.A

Address: 25 Mauchly, Suite 318, Irvine, CA92618, America
Tel: 1-949-608-7270
Fax: 1-949-608-7298
Website: <http://www.leadshineUSA.com>
Email: usa_sales@leadshine.com and cli@leadshine.com

Leadshine Hong Kong

Address: Rm 3, 9/F, Block E, Wah Lok Industrial Center,31-41 Shan Mei St., Fo Tan, Shatin, Hong Kong
Tel: 852-2952-9114
Fax: 852-2952-9395
Email: hk_sales@leadshine.com

EL5 Series High Voltage AC Servo Systems **5th Generation**



- High Performance
 - High Quality
 - Highly Cost-effective
- (Power range from 50W to 1,500W)

Note: Product appearance and technical parameters are subject to change without notice.



Company Overview

Founded in 1997, Leadshine Motion Technology Ltd. specializes in developing, manufacturing, and distributing high-quality cost-effective motion control products. Its products include motion controllers, stepper motors and drives, integrated steppers, easy servo motors and drives, integrated easy servos, servo motors and drives, integrated servos and power supplies. Leadshine serves various industrial and OEM customers in Asia, Europe, North/South America, Africa and Australia.

Leadshine is a global leader in stepper and servo technology, and it's also one of the LARGEST manufacturers of motion control products around the world. Led by an MIT PhD graduate, Leadshine's R&D team of 100 talented engineers is capable of designing high-quality motion control products based on the latest technologies. Leadshine's manufacturing facilities are ISO-9001 certified and professionally staffed.

Leadshine is committed to provide its customers with world-class motion control products at highly competitive prices. "LEADING technology and SHINING value" is always what Leadshine intends to offer to its customers.

R&D

Leadshine is proud of its talented research & development team, which is one of the best in the motion control industry. We are capable of designing world-class products which can meet high requirements of our customers. Many innovative designs and products from Leadshine have been awarded for patents by Chinese government.

Product Quality

Leadshine has been awarded the ISO 9001 registration for quality management practices since September 2004. The certification is a testimony of Leadshine's commitment to provide its customers with high quality products and services.

Technical Support

Staffed with a highly professional and experienced technical support team, Leadshine can help its customers to increase productivity, reduce design & selection risks, and minimize the product development time. We are able to support our customers through email, telephone, field support, product studying conference, and some other approaches.

You can contact Leadshine technical support by phone at 86-755-2641-8447, by fax at 86-755-2640-2718, or by email at tech@leadshine.com.



EL5 Series

CONTENTS

01 EL5 Series AC Servo Systems

- 1.1 Features
- 1.2 Typical Applications

02 EL5 Series Servo Drives

- 2.1 Part Number
- 2.2 Specifications
- 2.3 System Tuning and Configuration
- 2.4 Typical System Configuration
- 2.5 Wiring Example in Position Mode
- 2.6 Wiring Example in Velocity / Torque Mode
- 2.7 Mechanical Specifications

03 EL5 Series Servo Motors

- 3.1 Part Number
- 3.2 Electrical Specifications
- 3.3 Mechanical Specifications
- 3.4 Speed-Torque Curves

04 Accessories for the EL5 Series

05 Order Information



01 EL5 Series AC Servo Systems

1.1 Features

High Precision

- 17-bit (131,072 ppr) high resolution encoder optional.
- A standard EL5-M series motor come with a 2500-line (10000 ppr) encoder. However, motors come with 17-bit (131,072 ppr) high resolution encoders are also available for applications require higher precision, smoother movement and lower torque ripple.

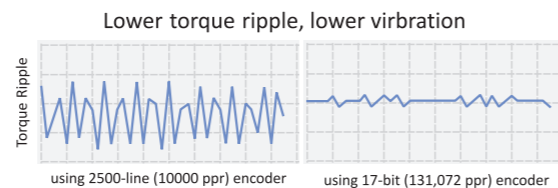

Excellent Position Following Capability

- By adopting load identification and torque feedforward advanced control algorithms, very small velocity ripple and position following error can be achieved. It is a great feature of the EL5 when multi-axis synchronization such as interpolations are required.

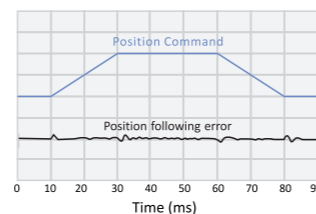

Quick Response

- Velocity response (bandwidth) up to 600 Hz.
- Takes only 10 ms from -3000 to 3000 rpm.

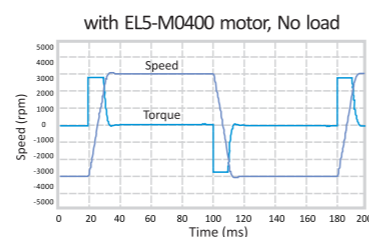

Vibration Suppression

- Adaptive filter makes the notch filter frequency automatically follow the machine resonance frequency.
- Can suppress vibration occurring at both starting and stopping in low stiffness machine.
- Suppress vibration frequency up to 1500 Hz

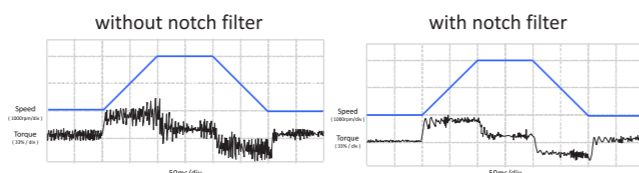

Command Signal Smoothing

- Command signal smoothing can soften the effect of immediate change in velocity and direction, delivering smoother movement and longer lifetime.

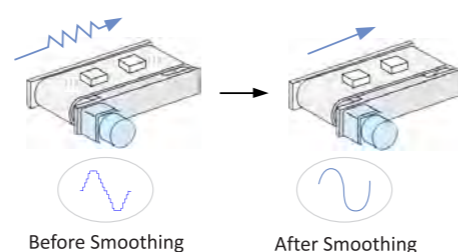

Built-in Regeneration Resistor

- A built-in regeneration resistor (except the EL5-D0400) can be used to absorb regenerative energy generated during motor deceleration, improving reliability of the servo systems. For additional protection or more regeneration energy need to be discharged, all EL5 series drives support using external regeneration resistor.

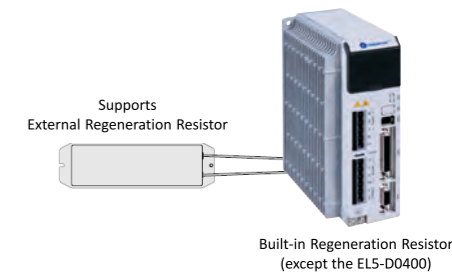

Servo Drive	Regeneration Resistor		
	Built-in	External (Typical)	Minimum*
EL5-D0400	-	80 Ω	40 Ω
EL5-D0750	50 Ω / 50W	200 Ω	40 Ω
EL5-D1000	50 Ω / 50W	120 Ω	30 Ω
EL5-D1500	50 Ω / 100W	120 Ω	30 Ω

*The minimum value of the regeneration resistor is equal to the value of the built-in resistor and external resistor in parallel.

1.2 Typical Applications

Packing Machines
Cutting Machines
Robots
Textile Machinery
CNC Machines
Printing Machines
Electronic Manufacturing
Punching Machines

High Precision
Highly Cost-effective
Compact Size
Quick Response

EL5 Series Servo Systems

02 EL5 Series Servo Drives

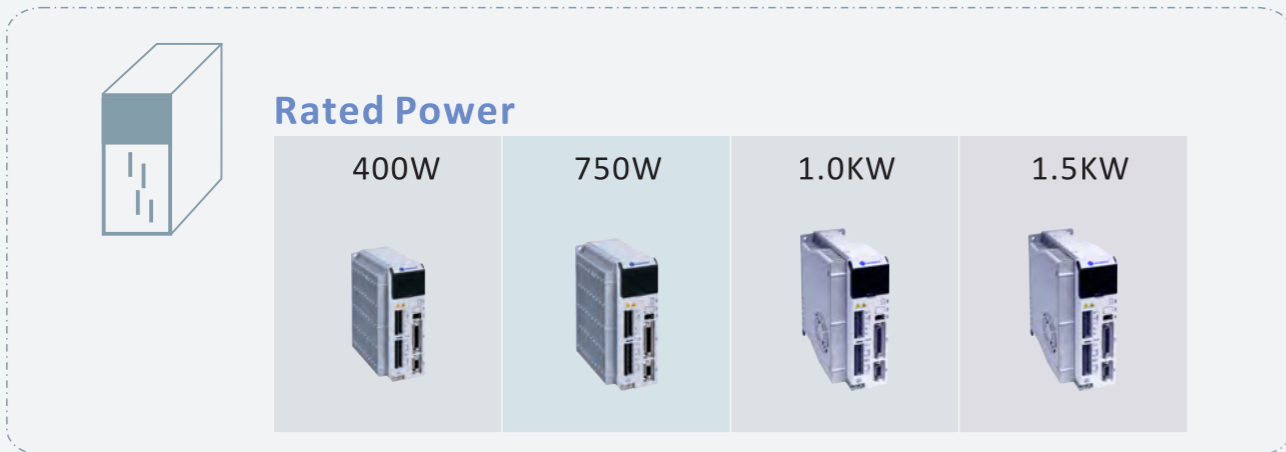

2.1 Part Number

EL5 — D 0750 — 1 — R

① ② ③ ④ ⑤

①	Series	EL5: EL5 Series
②	Product	D: Servo Drive M: Servo Motor
③	Power	0400: 400W 0750: 750W 1000: 1000W 1500: 1500W
④	Encoder Type	1: Incremental encoder (standard: 2500-line, 10,000 ppr) 2: Absolute encoder (standard: 17-bit, 131,072 ppr)
⑤	Communication or Motor Size	For servo drives, it is communication type. Blank: Step and direction only R: RS485 C: CANopen E: EtherCAT For servo motors, it is frame size. 16: NEMA16 (□40mm) 24: NEMA24 (□60mm) 32: NEMA32 (□80mm) 51: NEMA51 (□130mm)

2.2 Specifications

Electrical Specifications

Parameters	EL5-D0400	EL5-D0750	EL5-D1000	EL5-D1500
Maximum Continuous Power	400 W	750 W	1000 W	1500 W
Maximum Continuous Current	2 A	3.7 A	5 A	7.5 A
Peak Current	8 A	16 A	22 A	25 A
Main Supply Voltage	1 / 3 phase 220/230 VAC	1 / 3 phase 220/230 VAC	1 / 3 phase 220/230 VAC	1 / 3 phase 220/230 VAC
Power Supply for Control Circuit	1 phase 220 VAC	1 phase 220 VAC	1 phase 220 VAC	1 phase 220 VAC
Logical Signal Input Current	7 - 20 mA	7 - 20 mA	7 - 20 mA	7 - 20 mA
Auxiliary Power for Encoder	5 V @ 100 mA	5 V @ 100 mA	5 V @ 100 mA	5 V @ 100 mA

Control Specifications

Parameters	EL5-D0400	EL5-D0750	EL5-D1000	EL5-D1500
Command Input	Step/Direction	Step/Direction	Step/Direction	Step/Direction
	CW/CCW	CW/CCW	CW/CCW	CW/CCW
	± 10 V Analog	± 10 V Analog	± 10 V Analog	± 10 V Analog
Pulse Input Frequency	0 - 500 kHz	0 - 500 kHz	0 - 500 kHz	0 - 500 kHz
Position Loop Bandwidth	200 Hz	200 Hz	200 Hz	200 Hz
Velocity Loop Bandwidth	600 Hz	600 Hz	600 Hz	600 Hz
Speed Control Range	1:30000	1:30000	1:30000	1:30000
Electronic Gear Ratio	1/32767 - 32767	1/32767 - 32767	1/32767 - 32767	1/32767 - 32767
Enable/Disable Input	Differential	Differential	Differential	Differential
Alarm Signal Output	Isolated OC Output	Isolated OC Output	Isolated OC Output	Isolated OC Output
End Limit Input	Positive & Negative	Positive & Negative	Positive & Negative	Positive & Negative
In Position Signal Output	Isolated OC Output	Isolated OC Output	Isolated OC Output	Isolated OC Output
Encoder Feedback	2500-line or 17-bit	2500-line or 17-bit	2500-line or 17-bit	2500-line or 17-bit
Hall Effect Sensor Feedback	U, V, W (Differential)	U, V, W (Differential)	U, V, W (Differential)	U, V, W (Differential)
Encoder Output	A, B, Z (Differential)	A, B, Z (Differential)	A, B, Z (Differential)	A, B, Z (Differential)
Communication Interface	RS232 / RS485*	RS232 / RS485*	RS232 / RS485*	RS232 / RS485*
Regeneration Resistor	No Built-in Supports External	Built-in (50 ohm, 50W) Supports External	Built-in (50 ohm, 100W) Supports External	Built-in (50 ohm, 100W) Supports External

Mechanical Specifications

Parameters	EL5-D0400	EL5-D0750	EL5-D1000	EL5-D1500
Size (mm)	157.5 × 130 × 54	180 × 140 × 70	180 × 165 × 75	180 × 165 × 75
Weight (g)	1200	1500	1600	1600

Operating Environment

Cooling	Natural cooling or Forced cooling
Environment	Avoid dust, oil fog and corrosive gases
Operating Environment	Ambient Temp. 0 to +40 °C.
	Humidity 40% RH to 90%RH, no condensation
	Vibration 5.9 m/s ² MAX
Storage Temperature	-20 °C to 80 °C

* Available time for the servo drives which support CANopen and EtherCAT communication is to be determined.

2.3 System Tuning and Configuration

On-board HMI

7-segment highlight LED display, and functions the same as those of ProTuner.

"M" Button: Switch modes/menus.

"Ent" Button: Enter the parameter settings or set the values to the selected parameter and exit.

▲ UP Button: Increase the selected value by 1.

▼ DOWN Button: Decrease the selected value by 1.

◀ SHIFT Button: Press this to shift the digit for data change.



HMI

Tuning Via On-board HMI in JOG Mode

When the drive configured in JOG mode, the user can tune the servo system for his application without other controllers or command sources, such as external motion controllers or PC with ProTuner. For most of applications, configuration & tuning via on-board HMI should be enough to meet the application requirements. However, the user can also configure the advanced features or fine tune the system via ProTuner below.

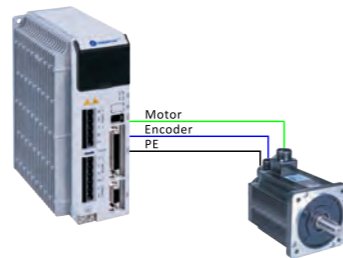

ProTuner (Windows Based Setup Software)

- Upload & Download parameter settings
- Digital oscilloscope for real-time current, velocity, position following error display.
- PID parameter settings for position loop
- PI parameter settings for velocity loop
- PI parameter settings for current loop
- Acceleration feed-forward, velocity feed-forward
- Motor parameter configuration
- Electronic gear rate
- Position following error range setting
- Encoder resolution setting
- Digital input and output settings
- Set parameters for simple motion test
- Read the latest 10 failure events and clear the events

Notes:

1. 1 PC RS232 interface or 1 USB port for USB-to-Serial converter is necessary.
2. Leadshine offers special cable for communication between ProTuner and the drive. See the accessories section for more information.

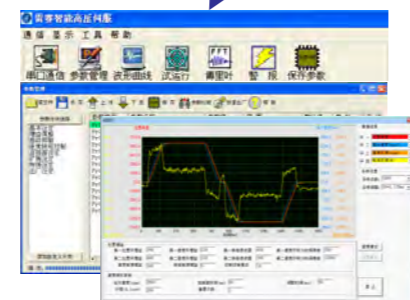
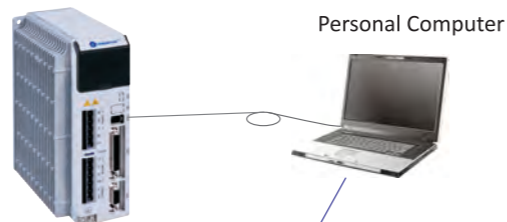

ProTuner

2.4 Typical System Configurations

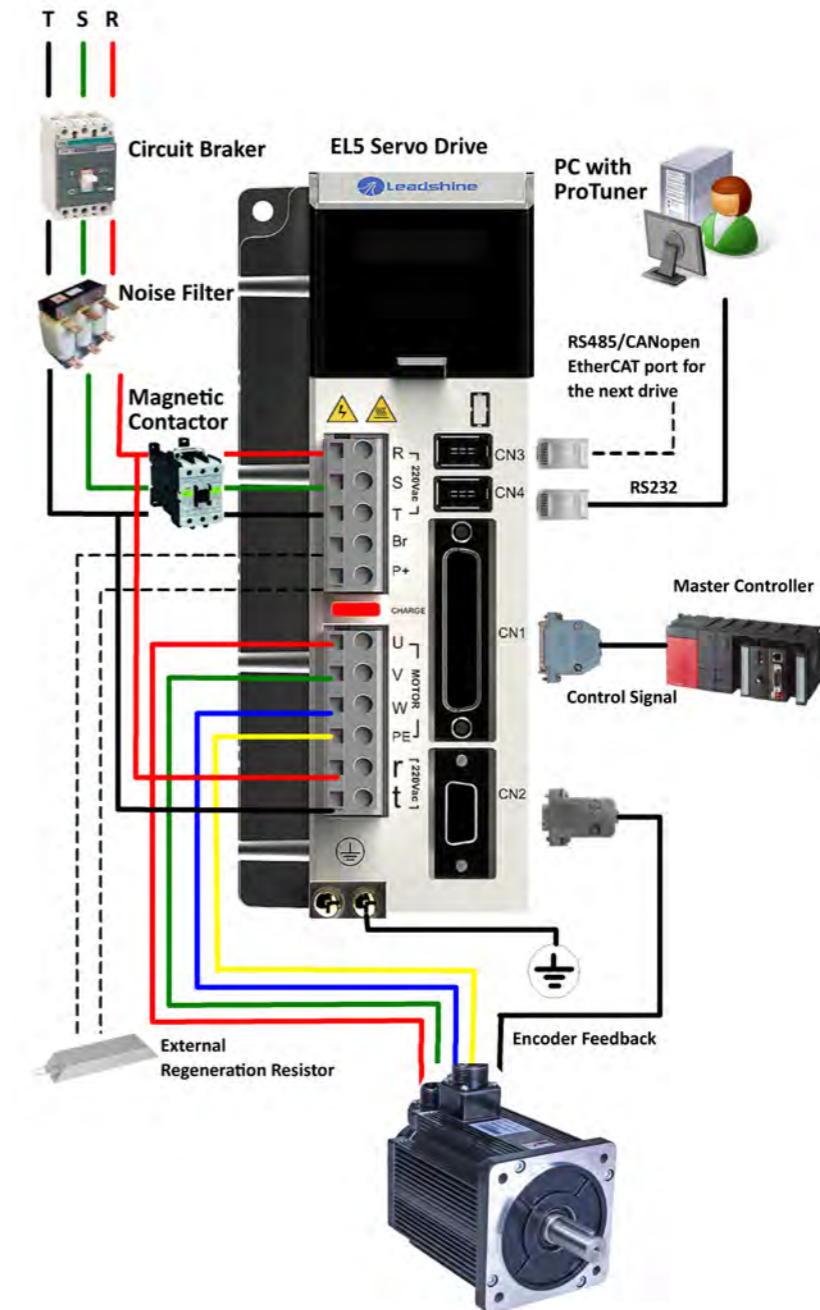

Notes:

1. DO NOT wiring the S phase if using a single-phase power supply.
2. DO NOT turn on power without first positively tightening all terminal block screws. Otherwise, loose contacts may generate heat (smoking, firing).
3. On some special occasions, the user can use the ALARM signal to switch servo drive off. Remember installation of a surge protector is required, and create the protective circuit.
4. DO remember to read User's Manual for a dedicated servo drive for more information about system configuration.

2.5 Wiring Example in Position Mode

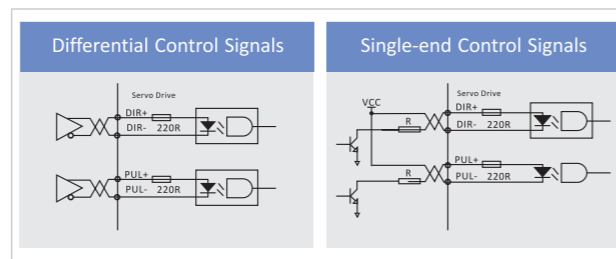
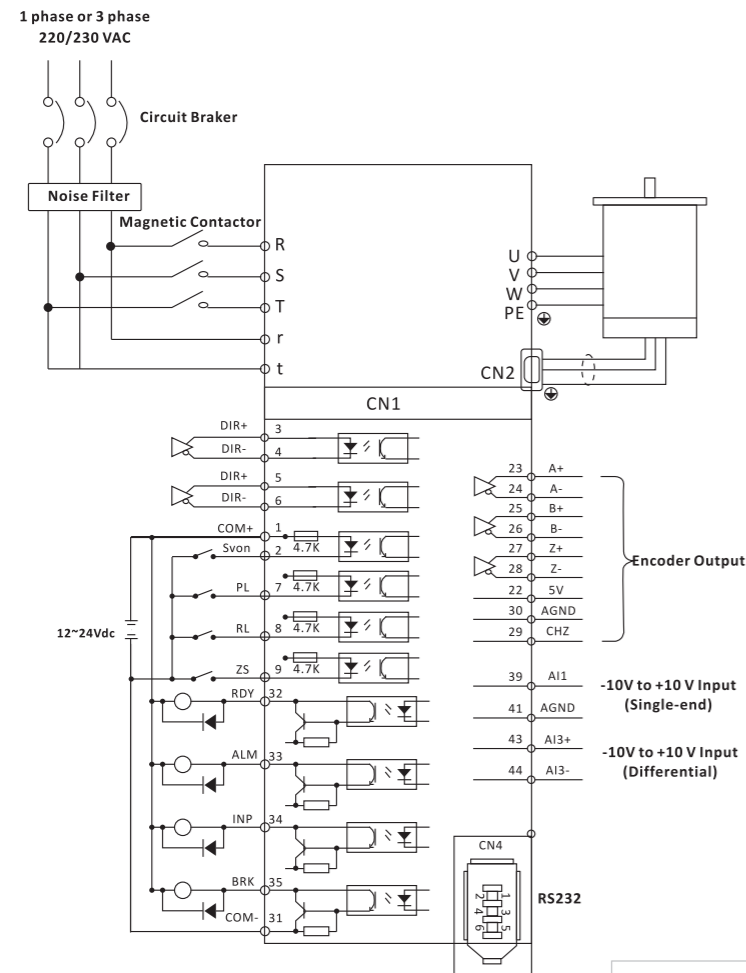

Notes:

1. Rated current of the external power supply (12 to 24 VDC) for digital inputs and outputs should more than 100mA.
2. Recommend use AWG24-26 shielded cables for control and feedback signals, and correctly ground the shielded cable.
3. Cable for control signals (CN1) should less than 3 meters, and cable for feedback signals (CN2) should less than 10 meters.
4. Recommend use an isolation transformer to supply the drive, and use a noise filter to protect the power line from external noise, and use a circuit breaker (NFB) to cut off power in the case of an overload, and use an electromagnetic contactor to switch servo power on and off.
5. Remember creat the protective circuit (a free wheeling diode control circuit) for digital outputs if they are used to control an inductive load.
6. The drive can accept differential and single-ended inputs, including open-collector and PNP output. Recommend use differential (line driver) control signals to increase noise immunity of the system.
7. Series connect resistors for current-limiting when +12V or +24V single-ended control signals are used. $R=1K$ (Power>0.25W), if $V_{cc}=12V$, and $R=2K$ (Power>0.25W), if $V_{cc}=24V$.

2.6 Wiring Example in Velocity / Torque Mode

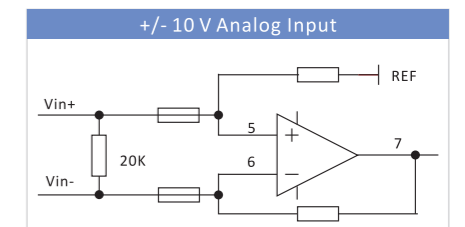
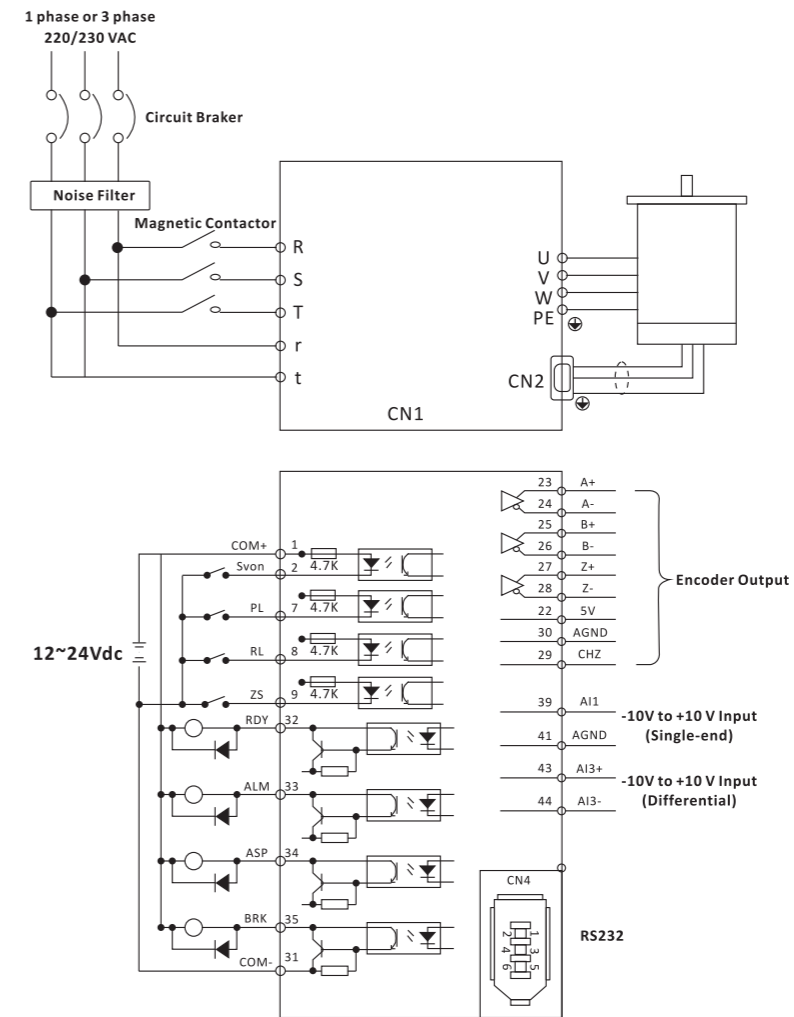

Notes:

1. Rated current of the external power supply (12 to 24 VDC) for digital inputs and outputs should more than 100mA.
2. Recommend use AWG24-26 shielded cables for control and feedback signals, and correctly ground the shielded cable.
3. Cable for control signals (CN1) should less than 3 m, and cable for feedback signals (CN2) should less than 20 m.
4. Recommend use an isolation transformer to supply the drive, and use a noise filter to protect the power line from external noise, and use a circuit breaker (NFB) to cut off power in the case of an overload, and use an electromagnetic contactor to switch servo power on and off.
5. Remember creat the protective circuit (a free wheeling diode control circuit) for digital outputs if they are used to control an inductive load.
6. Analog command should be between $-10V$ and $+10V$. Its input impedance is $20K\Omega$.

2.7 Mechanical Specifications

Units: mm 1 inch = 25.4 mm

100W/200W/400W

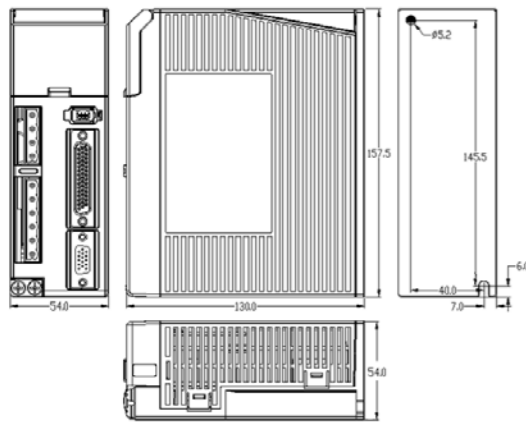

750W

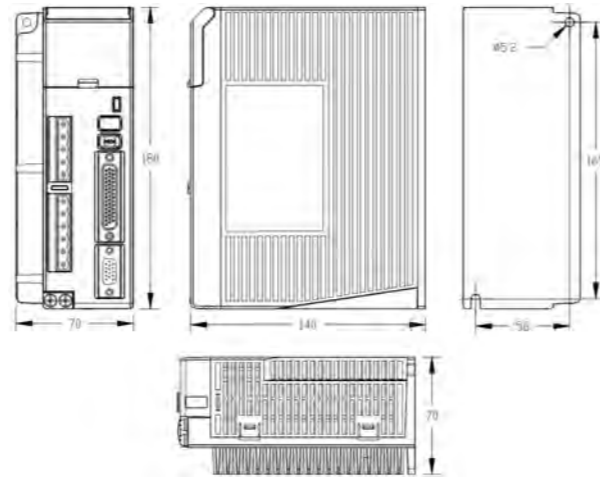

1KW/1.5KW

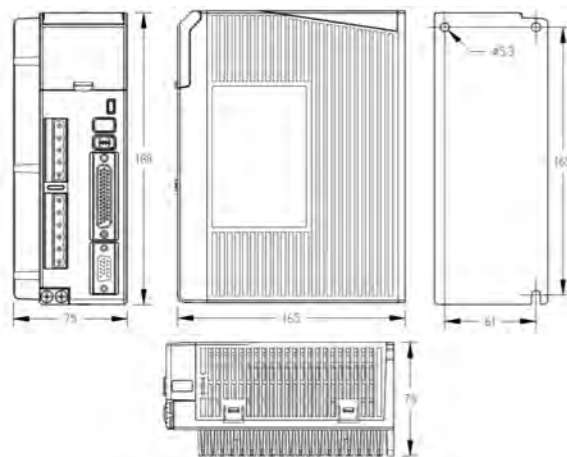

Installation Notes:

- (1) Install the drives indoors, where the drives are not subjected to rain or direct sun beams. The drives are not water proof.
- (2) Install the drives where the products are not subjected to corrosive atmospheres, and are free from splash of inflammable gas, grinding oil, oil mist, iron powder or chips and etc.
- (3) Install the drives in a well-ventilated and low humidity and dust-free place.
- (4) Do not give strong impact shock to the drive nor place the heavy object on them.
- (5) Install in vertical position, and reserve enough space around the servo drive for ventilation or effective cooling.
- (6) Keep the ambient temperature within the permissible temperature range (0 to 50°C) for the product. Use force cooling method if necessary.

03 EL5 Series Servo Motors

	Frame Size	40mm (NEMA16)	60mm (NEMA24)	80mm (NEMA32)	130mm (NEMA51)
	Rated Power	50W 100W	200W 400W 600W	750W 1.0KW	1.0 KW 1.5KW

3.1 Part Number

EL5 — **M** **0750** — **1** — **32**
 ① ② ③ ④ ⑤

①	Series	EL5: EL5 Series
②	Product	D: Servo Drive M: Servo Motor
③	Power	0400: 400W 0750: 750W 1000: 1000W 1500: 1500W
④	Encoder Type	1: Incremental encoder (standard: 2500-line, 10,000 ppr) 2: Absolute encoder (standard: 17-bit, 131,072 ppr)
⑤	Communication or Motor Size	For servo drives, it is communication type. Blank: Step and direction only R: RS485 C: CANopen E: EtherCAT For servo motors, it is frame size. 16: NEMA16 (□40mm) 24: NEMA24 (□60mm) 32: NEMA32 (□80mm) 51: NEMA51 (□130mm)

3.2 Electrical Specifications

NEMA16 (□ 40 mm)
Power: 50W, 100W



Specifications

Parameters	Units	EL5-M0050-x-16	EL5-M0100-x-16
Rated Power	W	50	100
Rated Torque	Nm	0.159	0.32
Rated Current	A	0.69	1.0
Rated Speed	RPm	3000	3000
Peak Torque	Nm	0.477	0.96
Peak Current	A	2.07	3.0
Torque Constant	Nm/A	0.23	0.32
Back EMF Constant	V/krpm	14.3	17
Inertia	Kg*m ² ×10 ⁻⁵	0.025	0.046
Poles	-	8	8

Operating Environment

Parameters	Descriptions	Parameters	Descriptions
Insulation Level	B	Insulation Voltage	AC1500V, 50Hz, 60seconds
Insulation Resistance	DC500V, above 10M Ω	Vibration	<2.5 G
Ambient Temperature	0 to 40°C	Humidity	20%RH to 90%RH
Storage Temperature	-20 to 70°C	Mounting Method	Flange Mounted

NEMA24 (□ 60 mm)
Power: 200W, 400W, 600W



Specifications

Parameters	Units	EL5-M0200-x-24	EL5-M0400-x-24	EL5-M0600-x-24
Rated Power	W	200	400	600
Rated Torque	Nm	0.64	1.27	1.9
Rated Current	A	2.1	2.8	4.5
Rated Speed	RPm	3000	3000	3000
Peak Torque	Nm	1.91	3.82	5.7
Peak Current	A	6.5	8.5	13.5
Torque Constant	Nm/A	0.31	0.47	0.47
Back EMF Constant	V/krpm	18.92	28.38	28.38
Inertia	Kg*m ² ×10 ⁻⁵	3.1	3.22	3.82
Poles	-	8	8	8

Operating Environment

Parameters	Descriptions	Parameters	Descriptions
Insulation Level	B	Insulation Voltage	AC1500V, 50Hz, 60seconds
Insulation Resistance	DC500V, above 10M Ω	Vibration	<2.5 G
Ambient Temperature	0 to 40°C	Humidity	20%RH to 90%RH
Storage Temperature	-20 to 70°C	Mounting Method	Flange Mounted

NEMA32 (□ 80 mm)
Power: 750W, 1000W

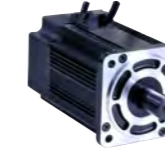

Specifications

Parameters	Units	EL5-M0750-x-32	EL5-M1000-x-32
Rated Power	W	750	1000
Rated Torque	Nm	2.4	3.2
Rated Current	A	4.4	5.9
Rated Speed	RPm	3000	3000
Peak Torque	Nm	7.2	9.6
Peak Current	A	13.4	17.7
Torque Constant	Nm/A	0.55	0.60
Back EMF Constant	V/krpm	33.1	36.03
Inertia	Kg*m ² ×10 ⁻⁵	7.3	8.5
Poles	-	8	8

Operating Environment

Parameters	Descriptions	Parameters	Descriptions
Insulation Level	B	Insulation Voltage	AC1500V, 50Hz, 60seconds
Insulation Resistance	DC500V, above 10M Ω	Vibration	<2.5 G
Ambient Temperature	0 to 40°C	Humidity	20%RH to 90%RH
Storage Temperature	-20 to 70°C	Mounting Method	Flange Mounted

NEMA51 (□ 130 mm)
Power: 1000W, 1500W



Specifications

Parameters	Units	EL5-M1000-x-51	EL5-M1500-x-51
Rated Power	W	1000	1500
Rated Torque	Nm	4.7	7.2
Rated Current	A	4.	14.2
Rated Speed	RPm	3000	3000
Peak Torque	Nm	14.1	21.3
Peak Current	A	28.2	42.6
Torque Constant	Nm/A	0.5	0.5
Back EMF Constant	V/krpm	39.3	44.1
Inertia	Kg*m ² ×10 ⁻⁵	85	201.7
Poles	-	10	10

Operating Environment

Parameters	Descriptions	Parameters	Descriptions
Insulation Level	B	Insulation Voltage	AC1500V, 50Hz, 60seconds
Insulation Resistance	DC500V, above 10M Ω	Vibration	<2.5 G
Ambient Temperature	0 to 40°C	Humidity	20%RH to 90%RH
Storage Temperature	-20 to 70°C	Mounting Method	Flange Mounted

3.3 Mechanical Specifications

Units: mm 1 inch = 25.4 mm

● EL5-M0050-x-16 and EL5-M0100-x-16

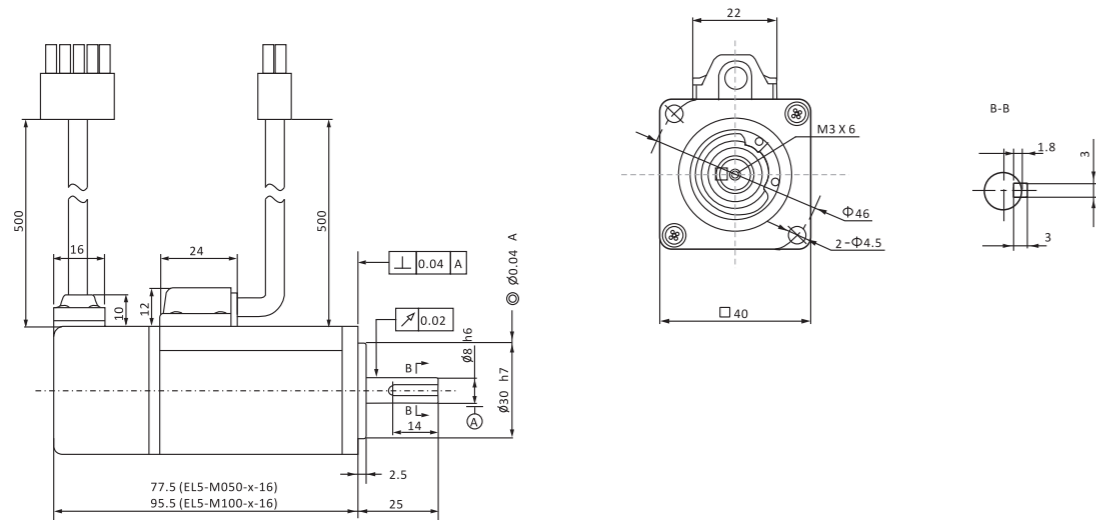

● EL5-M0200-x-24

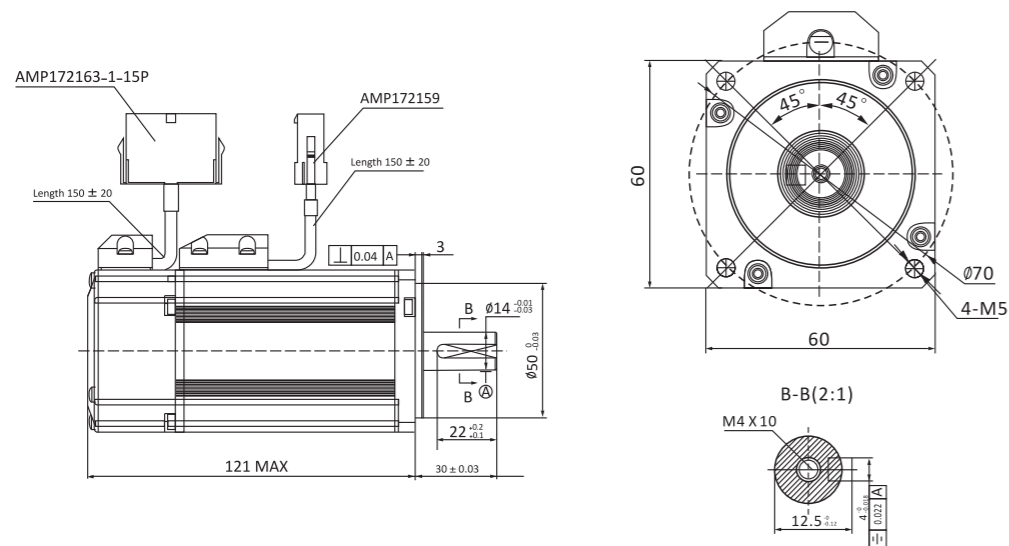

Installation Notes:

- (1) Do not give strong impact shock to the motor shaft.
- (2) Make sure the hall sensor signals U/V/W are connected to the drive correctly.
- (3) The motors are not water proof. Please contact Leadshine if you need a water proof product.
- (4) Keep the ambient temperature within the permissible temperature range (0 to 40 °C) for the product. Use force cooling method if necessary.

● EL5-M0400-x-24

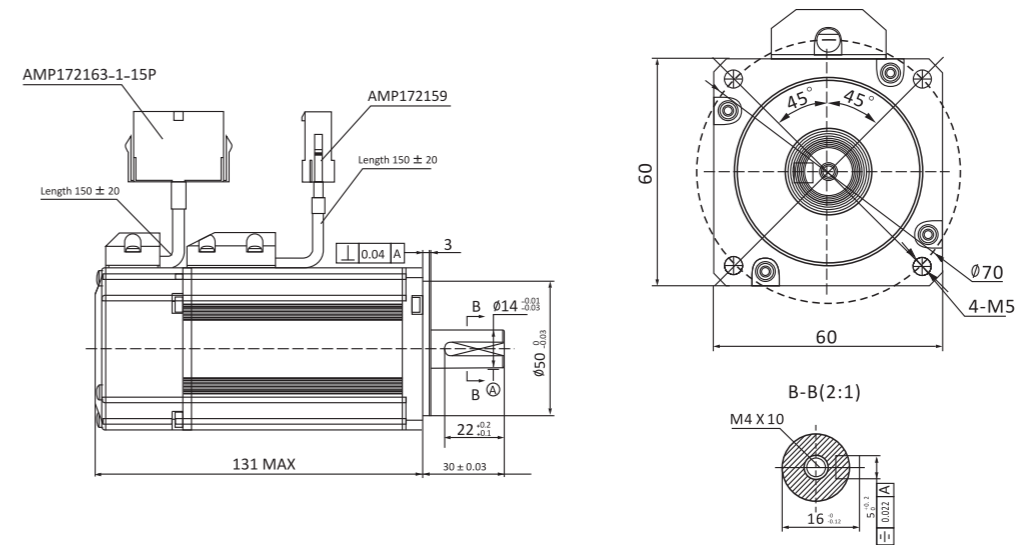

● EL5-M0600-x-24

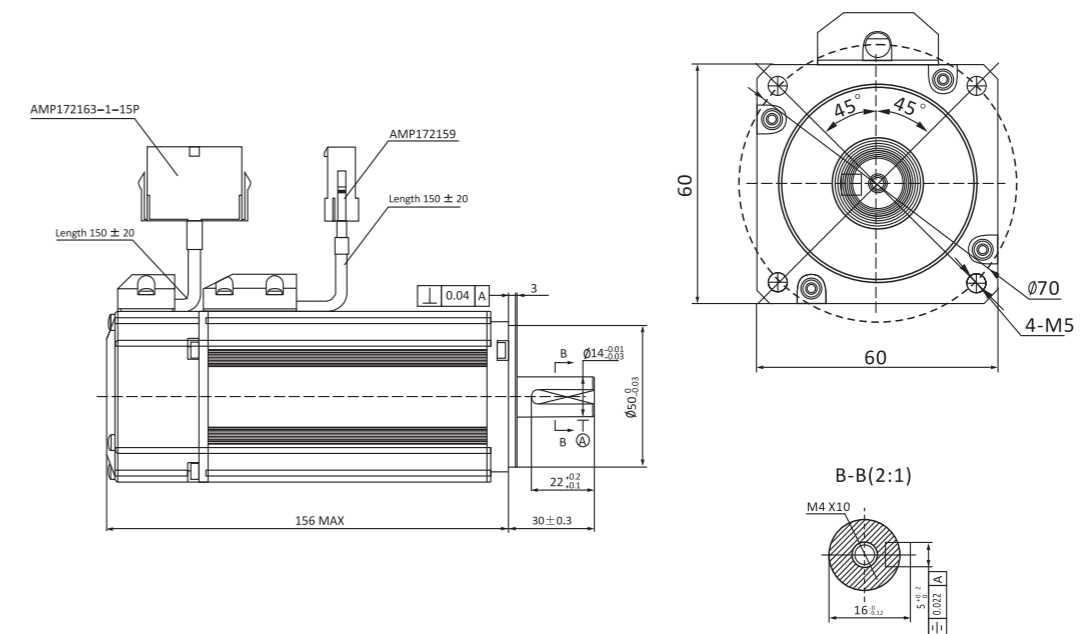

Installation Notes:

- (1) Do not give strong impact shock to the motor shaft.
- (2) Make sure the hall sensor signals U/V/W are connected to the drive correctly.
- (3) The motors are not water proof. Please contact Leadshine if you need a water proof product.
- (4) Keep the ambient temperature within the permissible temperature range (0 to 40 °C) for the product. Use force cooling method if necessary.

3.3 Mechanical Specifications (Con't)

Units: mm 1 inch = 25.4 mm

● EL5-M0750-x-32

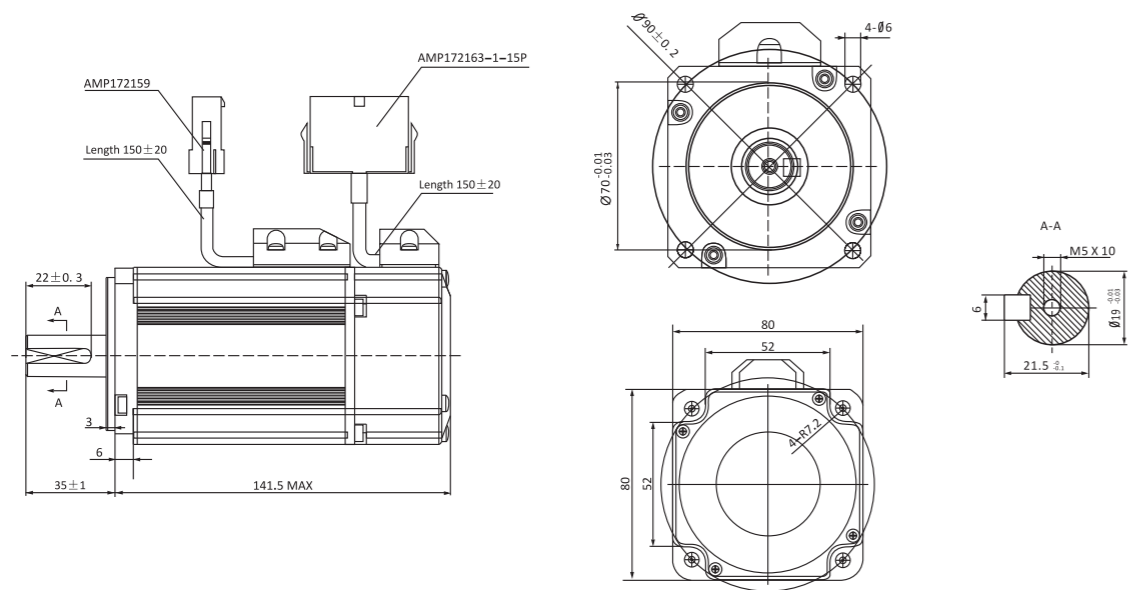

● EL5-M1000-x-32

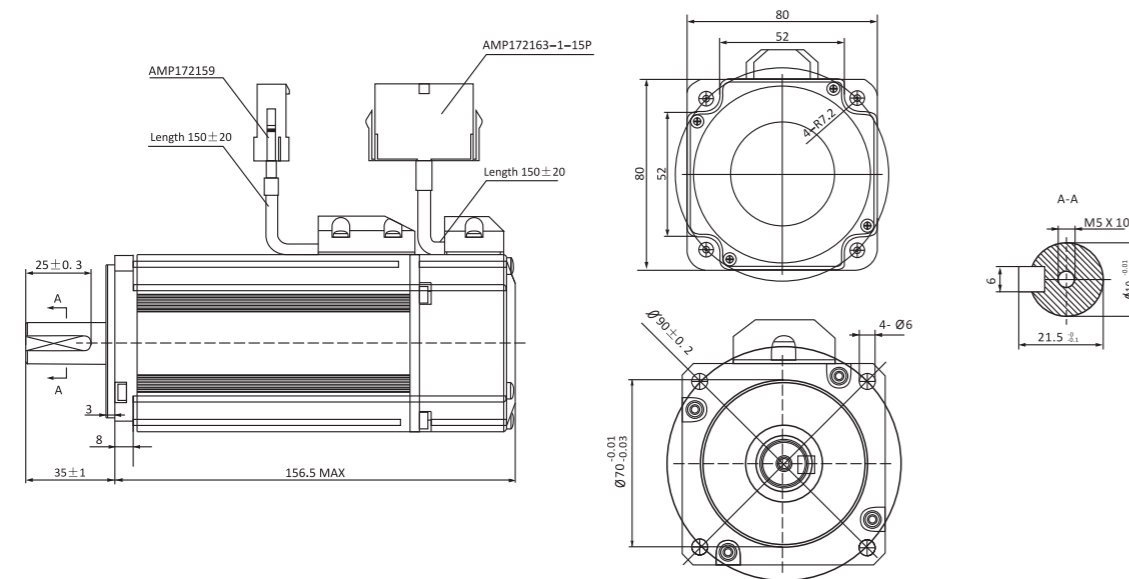

Installation Notes:

- (1) Do not give strong impact shock to the motor shaft.
- (2) Make sure the hall sensor signals U/V/W are connected to the drive correctly.
- (3) The motors are not water proof. Please contact Leadshine if you need a water proof product.
- (4) Keep the ambient temperature within the permissible temperature range (0 to 40 °C) for the product. Use force cooling method if necessary.

● EL5-M1000-x-51

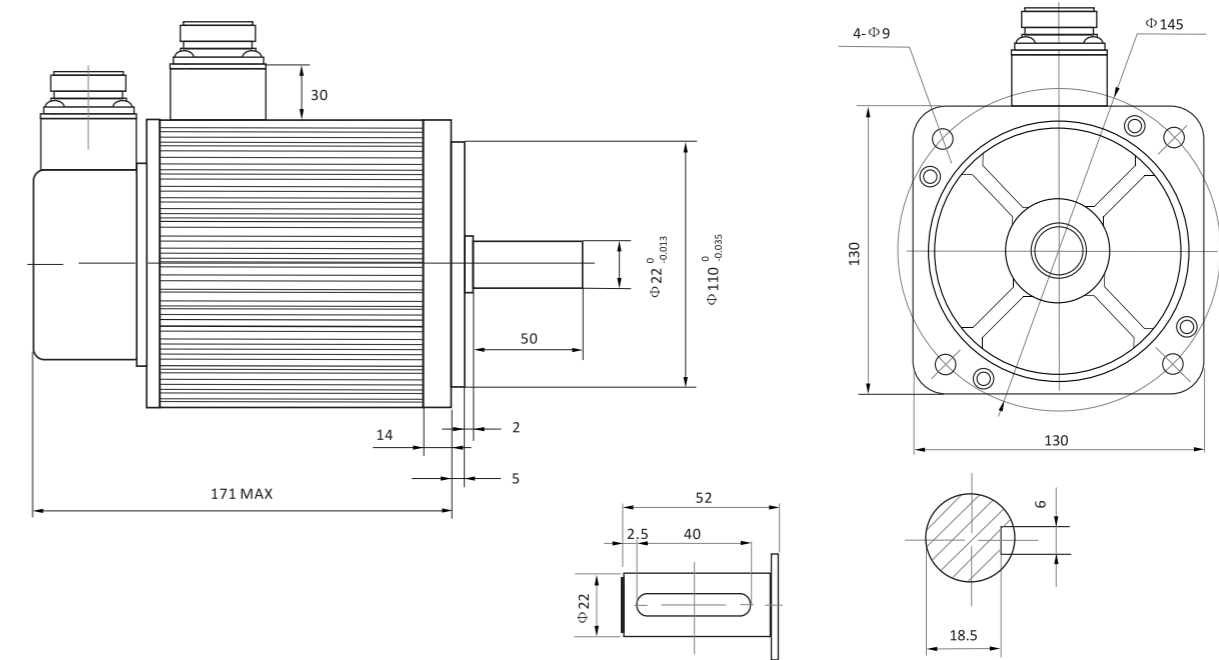

● EL5-M1500-x-51

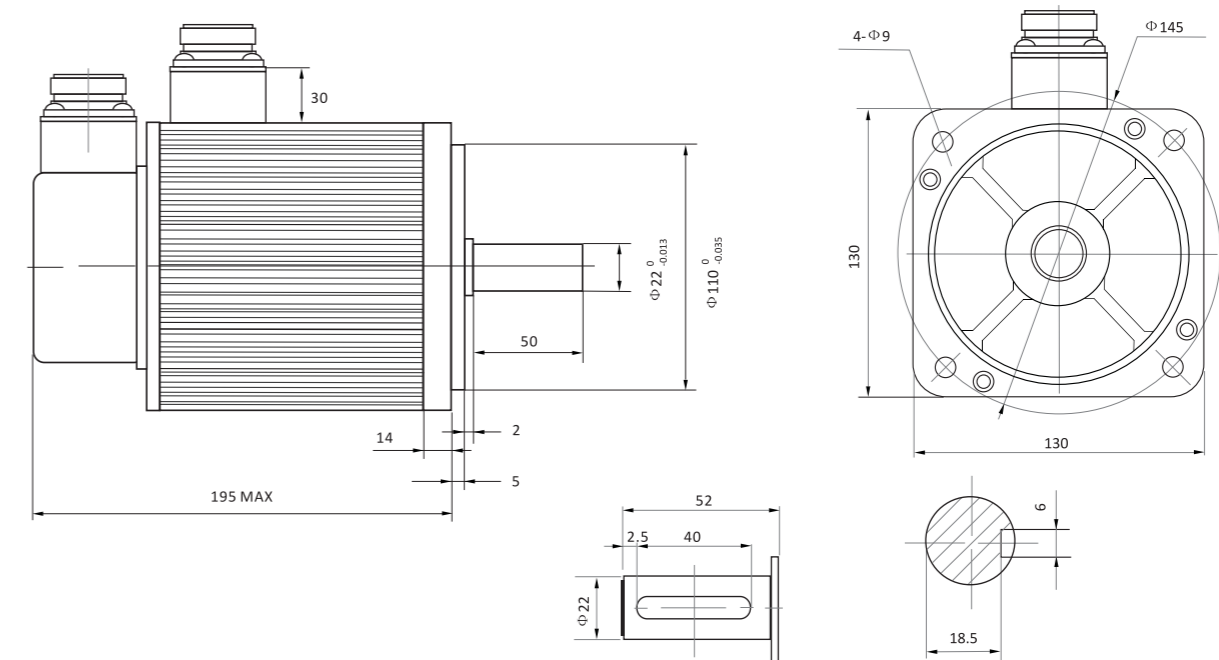

Installation Notes:

- (1) Do not give strong impact shock to the motor shaft.
- (2) Make sure the hall sensor signals U/V/W are connected to the drive correctly.
- (3) The motors are not water proof. Please contact Leadshine if you need a water proof product.
- (4) Keep the ambient temperature within the permissible temperature range (0 to 40 °C) for the product. Use force cooling method if necessary.

3.4 Speed-Torque Curves

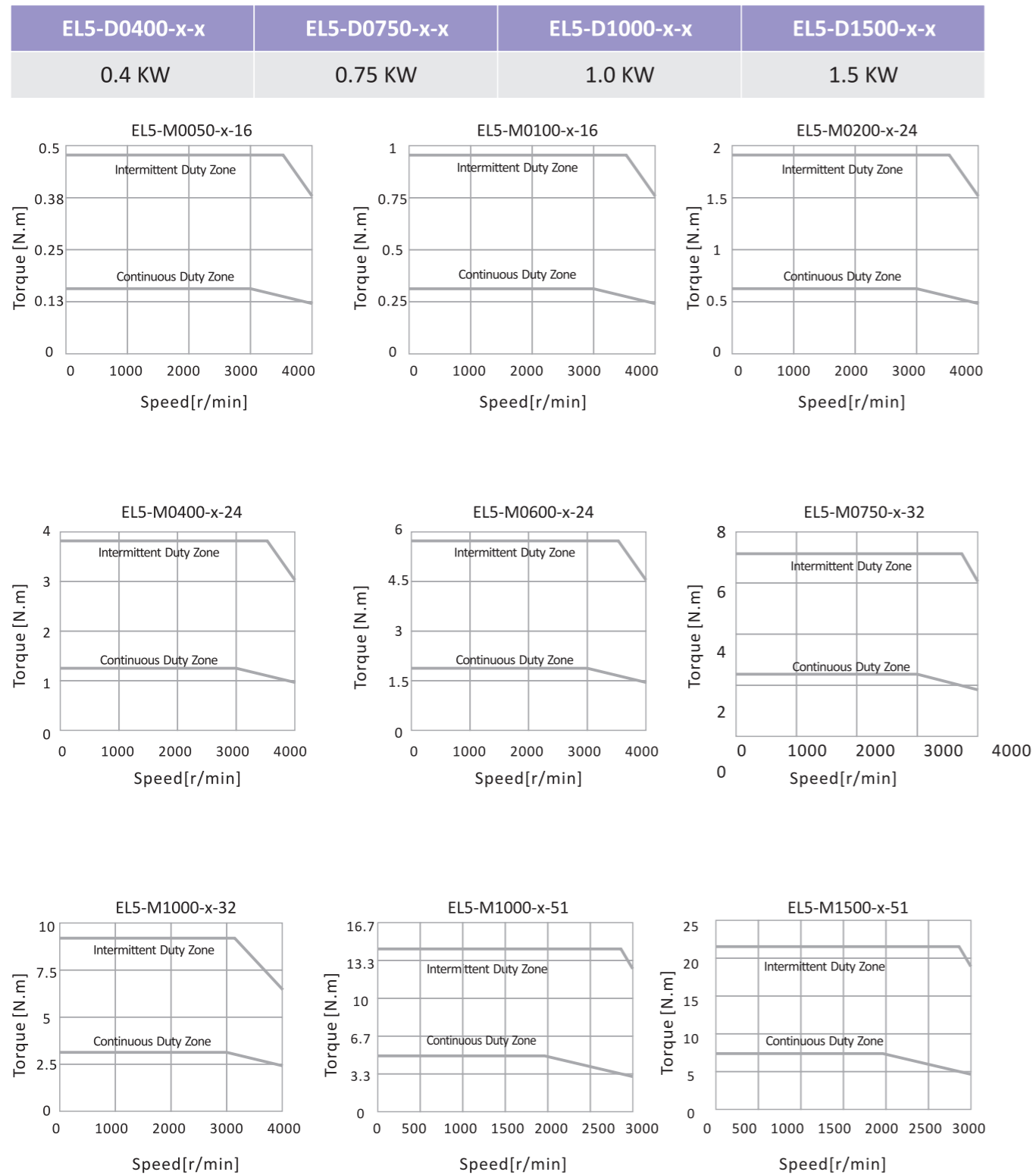

04 EL5 Series Accessories

Number	Picture	Name	Descriptions
1		Motor Cable: CABLE-RZ1M5-S (1.5m) CABLE-RZ3M0-S (3m) CABLE-RZ5M0-S (5m) CABLE-RZ10M0-S (10m)	Length 1.5m (Standard), 3m, 5m and 10m optional For NEMA16, NEMA24 and NEMA32 servo motors.
2		Motor Cable: CABLE-RZ1M5-H (1.5m) CABLE-RZ3M0-H (3m) CABLE-RZ5M0-H (5m) CABLE-RZ10M0-H (10m)	Length 1.5m (Standard), 3m, 5m and 10m optional For NEMA51 servo motors.
3		Encoder Cable: CABLE-BM1M5-S (1.5m) CABLE-BM3M0-S (3m) CABLE-BM5M0-S (5m) CABLE-BM10M0-S (10m)	Length 1.5m (Standard), 3m, 5m and 10m optional For NEMA16, NEMA24 and NEMA32 servo motors.
4		Encoder Cable: CABLE-BM1M5-H (1.5m) CABLE-BM3M0-H (3m) CABLE-BM5M0-H (5m) CABLE-BM10M0-H (10m)	Length 1.5 m (Standard), 3m, 5m and 10m optional For NEMA51 servo motors.
5		RS232 Cable for ProTuner: CABLE-ACH1000	Length 1.2 m, For the EL5 series servo drives.
6		Control Signal Connector: HDB-44P	Control signal connector for the EL5 series servo drives
7		USB to RS232 Converter: NOT a standard accessory. .	Please specify when place an order if you need.
8		External Regeneration Resistor: NOT a standard accessory.	Please specify when place an order if you need.

04 Accessories (Con't)

Motor Cable

Motor Cable (for NEMA16 to NEMA32 motors)

Model: CABLE-RZ1M5-S, CABLE-RZ3M0-S, CABLE-RZ5M0-S, CABLE-RZ10M0-S

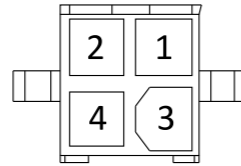

Pin	Name
1	V
2	U
3	W
4	PE

Motor Cable (for NEMA51 motors)

Model: CABLE-RZ1M5-H, CABLE-RZ3M0-H, CABLE-RZ5M0-H, CABLE-RZ10M0-H

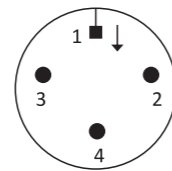
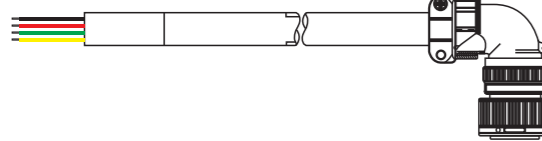

Pin	Name
1	PE
2	U
3	V
4	W

Encoder Cable

Encoder (for NEMA16 to NEMA32 motors)

Model: CABLE-BM1M5-S, CABLE-BM3M0-S, CABLE-BM5M0-S, CABLE-BM10M0-S

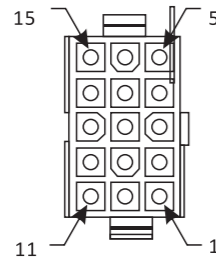
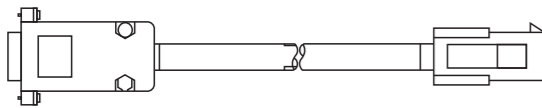

Pin	Name	Pin	Name
1	PE	5	Z-
2	+5V	6	HU+
3	GND	8	HU-
9	EA+	10	HV+
13	EA-	12	HV-
4	EB+	11	HW+
14	EB-	15	HW-
7	Z+		

Encoder Cable (for NEMA51 motors)

Model: CABLE-BM1M5-H, CABLE-BM3M0-H, CABLE-BM5M0-H, CABLE-BM10M0-H

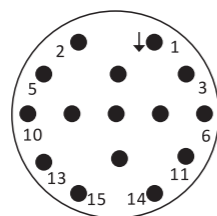
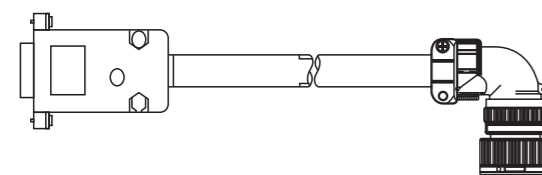

Pin	Name	Pin	Name
1	PE	9	Z-
2	+5V	10	HU+
3	GND	11	HU-
4	EA+	12	HV+
5	EA-	13	HV-
6	EB+	14	HW+
7	EB-	15	HW-
8	Z+	16	NC

05 EL5 Series Order Information

Power	Package	Drive	Motor	Standard Accessories
50 W	EL5-P0050-x-x	EL5-D0400-x-x	EL5-M0050-x-16	CABLE-RZ1M5-S CABLE-BM1M5-S CABLE-ACH1000 HDB-44P See "Accessories" section for more information.
100 W	EL5-P0100-x-x	EL5-D0400-x-x	EL5-M0100-x-16	CABLE-RZ1M5-S CABLE-BM1M5-S CABLE-ACH1000 HDB-44P See "Accessories" section for more information.
200 W	EL5-P0200-x-x	EL5-D0400-x-x	EL5-M0200-x-24	CABLE-RZ1M5-S CABLE-BM1M5-S CABLE-ACH1000 HDB-44P See "Accessories" section for more information.
400 W	EL5-P0400-x-x	EL5-D0400-x-x	EL5-M0400-x-24	CABLE-RZ1M5-S CABLE-BM1M5-S CABLE-ACH1000 HDB-44P See "Accessories" section for more information.
600 W	EL5-P0600-x-xxx	EL5-D0750-x-x	EL5-M0600-x-24	CABLE-RZ1M5-S CABLE-BM1M5-S CABLE-ACH1000 HDB-44P See "Accessories" section for more information.
750 W	EL5-P0750-x-x	EL5-D0750-x-x	EL5-M0750-x-32	CABLE-RZ1M5-S CABLE-BM1M5-S CABLE-ACH1000 HDB-44P See "Accessories" section for more information.
1000 W	EL5-P1000-x-x (NEMA32)	EL5-D1000-x-x	EL5-M1000-x-32	CABLE-RZ1M5-S CABLE-BM1M5-S CABLE-ACH1000 HDB-44P See "Accessories" section for more information.
1000 W	EL5-P1000-x-x (NEMA51)	EL5-D1000-x-x	EL5-M1000-x-51	CABLE-RZ1M5-H CABLE-BM1M5-H CABLE-ACH1000 HDB-44P See "Accessories" section for more information.
1500 W	EL5-P1500-x-x	EL5-D1500-x-x	EL5-M1500-x-51	CABLE-RZ1M5-H CABLE-BM1M5-H CABLE-ACH1000 HDB-44P See "Accessories" section for more information.

Package Number

EL5	-	P	-	1500	-	1	-	R
EL5: EL5 Series		P: Package		Rated Power: 1500: 1500W		Encoder Type: 1: Incremental encoder (2500-line) 2: Absolute encoder (17-bit)		Communication: Blank: RS485 R: RS485 C: CANopen E: EtherCAT