

Global Footprint

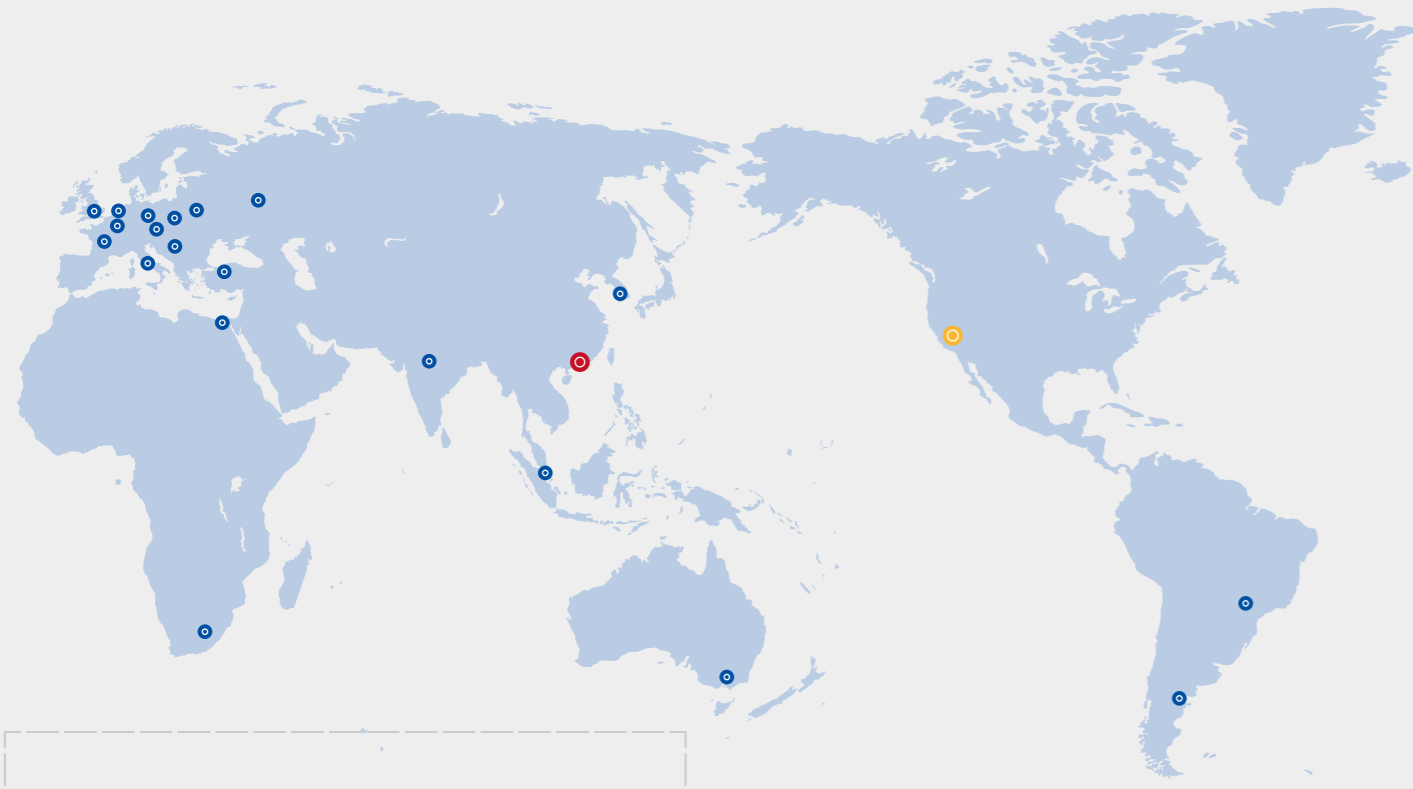

Headquarters Leadshine Technology Co., Ltd.

Address: Floor 11, Block A3, iPark, 1001 Xueyuan Blvd.
Nanshan District Shenzhen, Guangdong
518055 China
Tel: +86 755 26411692
Fax: +86 755 26402718
Website: www.leadshine.com
Emails: sales@leadshine.com (Sales)
tech@leadshine.com (Technical Support)

North America Office Leadshine America, Inc.

Address: 26050 Towne Centre Dr.
Foothill Ranch, CA 92610
USA
Tel: 1-949-608-7270
Fax: 1-949-638-7298
Website: www.Leadshineusa.com
Emails: sales@leadshineusa.com (Sales)
tech@leadshineusa.com (Technical Support)



STEPPER PRODUCTS

- Stepper Drives
- Stepper Motors
- Closed Loop Stepper Drives
- Closed Loop stepper Motors
- Integrated Stepper Motors
- Gearboxes
- Power Supplies



COMPANY PROFILE

Founded in 1997 by Dr. Warren Li, a MIT PhD graduate. Leadshine Technology Co., Ltd. is a leading technology company dedicated to designing, manufacturing, marketing affordable high performance motion control products based on the latest control technologies.

Our products include stepper and closed loop stepper motors & AC servo motors & drives, integrated stepper & servo motors, motion controllers, motion PLCs, etc.

Today, Leadshine is a publicly listed company (stock code 002979) with over 1,000 employees and 4 manufacturing facilities in China. We are the largest stepper product manufactures in China, and serve 10,000+ OEM clients from 60+ countries and in tens of industries.



Leadshine Headquarters in Shenzhen



Motor Factory in Shanghai



Factory in Shenzhen

R&D

Led by Dr. Li, a PhD majored in robotics & servo controls from MIT, Leadshine has one of the strongest R&D teams in the motion control industry.

The team consists of more than 100 R&D engineers and all of them are highly educated with most of them carry PhD & Master degrees in automatic control, electrical & electronics engineering, mechanical engineering, mechatronics, computer engineering, and computer science.

Their strong background and experience allow Leadshine capable of designing superior quality products based the latest technology in the most efficient way.

Product Quality

Leadshine operates manufacturing facilities which are superiorly equipped, professionally staffed, and ISO-9001 certified. That allows Leadshine to provide highly reliable quality motion control products OEM clients in the shortest time.

Leadshine's products have proven records of being successfully adapted in thousands of applications such as CNC routers, mills, plasmas, lathes, laser cutters/engravers/markers, inkjet printers, plotters, electronics equipments, medical equipments, semiconductor assembly & inspection machines, electronics machines, packaging equipments, textile machines, robotics, pick-and-place devices, etc. In most cases, Leadshine's standard "off-the-shelf" products are able to satisfy the motion control needs for most applications.

For many OEM applications with special requirements, Leadshine also offers customized products with optimized performance.

Support and Service

Leadshine believes the key to be a successful motion product supplier is the commitment to fully understanding our customer's applications and working closely with our OEM clients.

In many cases, Leadshine engineers can participate in the whole process of client product development, including initial application evaluation, product selection, design help & suggestion.

Our expertise and experience allow us to help OEM clients to produce competitive high quality machines in their industries.

MILESTONE

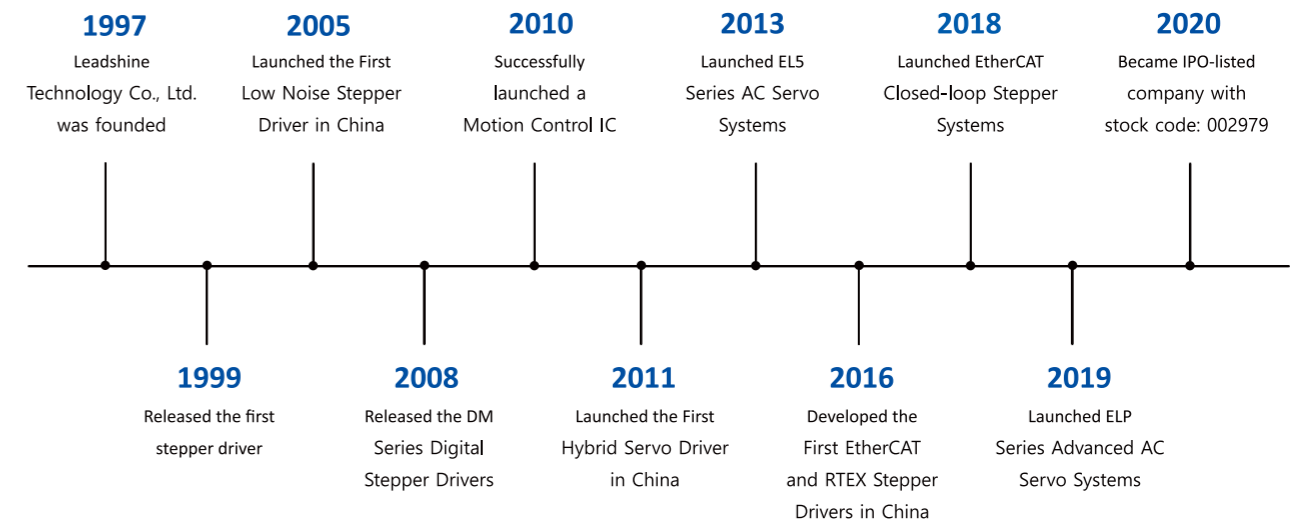

Why Leadshine

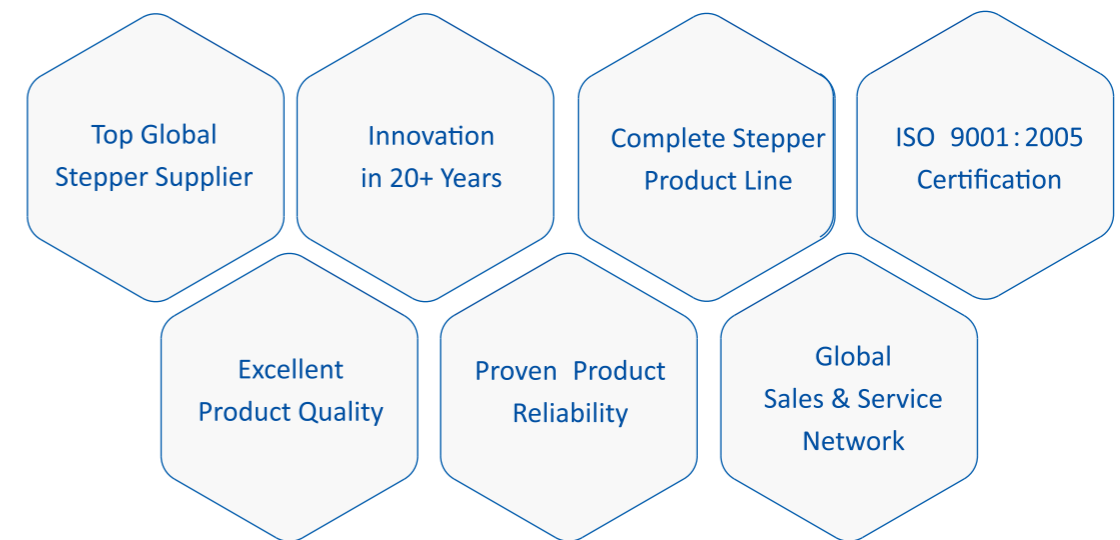

20,000,000+ controlled Stepper Axes in the Field Since 1997!

Industry applications



ELECTRONIC MANUFACTURING EQUIPMENT

- Dispensing machine
- SMT
- Battery industry
- Screw locking machine
- Wire stripping machine



LASER MACHINE INDUSTRY

- Laser marking machine
- Jade carving machine
- Laser cutting machine
- Wood carving machine



SPECIAL MACHINE TOOL INDUSTRY

- CNC machine
- Die stamping machine



PACKAGING INDUSTRY

- Food packaging equipment
- Beverage packaging equipment



TEXTILE AND GARMENT INDUSTRY

- Computer cutting plotter
- Garment proofing machine
- Vertical jet cutting machine
- Template cutting machine
- Pattern cutting machine



MEDICAL AND HEALTH INDUSTRY

- Biochemical analyzer
- Mask machine
- Urine analyzer
- Peristaltic pump
- Blood sample analyzer

PRODUCT OVERVIEW

Network Stepper Drives



EM3E Series

- Input Voltage:**
- 20-50VDC, 20-80VDC
 - 30-110VDC or 20-80VAC
- Control Mode:**
- EtherCAT
- Inputs and Outputs:**
- EM3E-522/556/870: 5 digital inputs, 2 digital outputs
 - EM3E-A882: 7 digital inputs, 6 digital outputs

Fieldbus Stepper Drives



EM2RS Series



EM-CAN Series

- Input Voltage:**
- 20-50VDC
 - 30-110VDC or 20-80VAC
- Control Mode:**
- RS485 Modbus
 - CANopen Fieldbus
- Inputs and Outputs:**
- EM2RS-522/556/870: 7 digital inputs, 3 digital outputs
 - EM522-CAN/556-CAN: 3 digital inputs, 1 digital outputs
 - DMA882-CAN: 4 digital inputs, 2 digital outputs

Pulse Control Stepper Drives

Step & Direction



EM-S Series



DM-E Series

- Input Voltage:**
- 12-40VDC, 20-50VDC, 20-80VDC
- Control Mode:**
- EM-S: Step&Direction, CW&CCW
 - DM-E: Step&Direction
- Inputs and Outputs:**
- EM415S/422S/882S: 3 digital inputs, 1 digital outputs
 - EM542S/556S/870S: 3 digital inputs, 2 digital outputs
 - DM322E/332E/542E/556E/860E/A860E: 3 digital inputs

Special Type Stepper Drives

Step & Direction I/O



DM Series



DM-IO Series

- Input Voltage:**
- 20-50VDC, 20-80VDC
 - 20-80VAC or 30-110VDC
 - 110±10%VAC, 220±10% VAC
- Control Mode:**
- DM Series: AC input or 3-phase type
 - DM-IO Series: I/O digital control
 - DM805-AI: Step&Direction, 0-5V analog control
 - 3DM series: Step&Direction, CW&CCW

Standard Stepper Motors

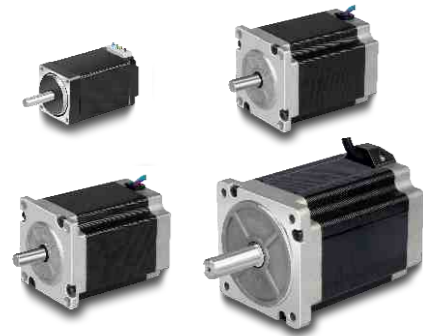

CM Series

Frame Size:

- From NEMA 08(20mm) to NEMA 51(130mm)
- 2-phase: 20mm, 28mm, 35mm, 42mm, 57mm, 60mm, 86mm, 110mm, 130mm
- 3-phase: 57mm, 86mm, 110mm

Option Type:

- Dual shaft
- Encoder
- Brake
- IP65 waterproof
- Gearbox

Vector Control Easy Servo Drives



ES2 Series

Input Voltage:

- 20-50VDC
- 30-110VDC or 20-80VAC
- 110VAC±10%, 220VAC±10%

Control Mode:

- Step&Direction
- CW&CCW

Inputs and Outputs:

- 3 digital inputs, 2 digital outputs
- Encoder outputs

Network Closed Loop Stepper Drives



CS3E Series

Input Voltage:

- 20-50VDC
- 30-110VDC or 20-80VAC

Control Mode:

- EtherCAT

Inputs and Outputs:

- CS3E-D503/507/1008: 7 digital inputs/7 digital outputs

Closed Loop Stepper Motors



CS-M Series & ES2-MH Series

Frame Size and Encoder:

- 20mm: 1000 ppr
- 28mm: 1000/2500/5000 ppr
- 42mm: 1000/2500/5000 ppr
- 57mm: 1000/2500/5000 ppr
- 60mm: 1000/2500/5000 ppr
- 86mm: 1000/5000 ppr
- 110mm: 1000 / 5000 ppr

Option Type:

- Brake
- IP65 waterproof
- Gearbox

Fieldbus Closed Loop Stepper Drives



CS2RS Series

Input Voltage:

- 20-50VDC
- 30-110VDC or 20-80VAC

Control Mode:

- RS485 Modbus

Inputs and Outputs:

- CS2RS-D503/507: 7 digital inputs, 3 digital outputs
- CS2RS-D1008: 7 digital inputs, 3 digital outputs

Integrated Stepper Motors



Integrated Stepper Motors

Input Voltage:

- 20-50VDC

Control Mode:

- iST/iEM: open loop control
- iES/iCS: closed loop control
- Step&Direction, RS485, CANopen

Inputs and Outputs:

- iST / iES: 3 digital inputs, 2 digital outputs
- iEM / iCS: 3 digital outputs, 1 digital outputs

Pulse Control Closed Loop Stepper Drives



CS1 Series

CS-D Series

Input Voltage:

- 20-50VDC
- 20-80VAC or 30-110VDC

Control Mode:

- Step&Direction
- CW&CCW

Inputs and Outputs:

- CS1-D503S/507S: 4 digital inputs, 3 digital outputs, encoder outputs
- CS-D403/CS-D508: 3 digital outputs, 1 digital outputs
- CS-D808/CS-D1008: 3 digital outputs, 1 digital outputs

Other Products



LSP Series
Power Supplies

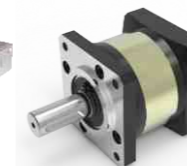

PLF Series
Gearboxes

Power Supplies:

- 220VAC±10% or 110VAC±10% input
- 24VDC/36VDC/48VDC/60VDC output







Gearboxes:

- 42mm: 1:5, 1:10, 1:20
- 60mm: 1:3, 1:5, 1:7, 1:10
- 90mm: 1:3, 1:5, 1:7, 1:10

Leadshine Stepper Products Quick Selection





Stepper drive quick selection table

☑ : Support ☐ : Not Support

Series	Picture	Model	Matched Motor Series	Control Type					Electrical Parameters			Motion Function Features					I/O		Others				
				EtherCAT	RS485 Modbus	Step&Dir	CW&CCW	Others	Power Voltage	Output Current	Logical Voltage	Alarm Output	Brake Output	Self Test	Anti-resonance	Auto-tuning Disable	Digital Input	Digital Output	Mechanical Size (mm)	Tuning Cable	Tuning Software		
EM3E		EM3E-522E	CM Series	☑					20-50VDC	0.3-2.2A	12-24V		☑	☑	☑	☑	☑	6	2	118*90*34	CABLE-MUSB1M5	Leadshine MotionStudio	
		EM3E-556E		☑					20-50VDC	2.1-5.6A	12-24V		☑	☑	☑	☑	☑	6	2	118*90*34			
		EM3E-870E		☑					20-80VDC	2.1-7.0A	12-24V		☑	☑	☑	☑	☑	6	2	118*90*34			
		EM3E-A882		☑					18-80VAC 30-110VDC	2.1-8.2A	12-24V		☑	☑	☑	☑	☑	7	7	151*113*40			Standard ProTuner
EM2RS		EM2RS-522			☑					20-50VDC	0.3-2.2A	12-24V		☑	☑	☑	☑	☑	7	3	118*79.5*25.5	CABLE-PC-1	Leadshine MotionStudio
		EM2RS-556			☑					20-50VDC	0.5-5.6A	12-24V		☑	☑	☑	☑	☑	7	3	118*79.5*25.5		
		EM2RS-870			☑					20-80VDC	0.5-7.0A	12-24V		☑	☑	☑	☑	☑	7	3	118*79.5*25.5		
		EM2RS-A882			☑					18-80VAC 30-110VDC	0.5-8.2A	12-24V		☑	☑	☑	☑	☑	7	3	151*97*53		
EM-S		EM415S(V2.0)				☑	☑			12-40VDC	0.3-1.5A	5V		☑		☑	☑	☑	3	1	86*55*20	CABLE-PC-1	Standard ProTuner
		EM422S(V2.0)				☑	☑			12-40VDC	0.3-2.2A	5V		☑		☑	☑	☑	3	1	86*55*20		
		EM432S				☑	☑			12-40VDC	0.3-3.2A	5V		☑		☑	☑	☑	3	1	86*55*20		
		EM542S(V3.0)				☑	☑			20-50VDC	0.5-4.2A	5 / 24V		☑	☑	☑	☑	☑	3	2	118*75.5*25.5		
		EM556S(V3.0)			☑	☑			20-50VDC	0.5-5.6A	5 / 24V		☑	☑	☑	☑	☑	3	2	118*75.5*34			
		EM870S(V3.0)			☑	☑			20-80VDC	0.5-7.0A	5 / 24V		☑	☑	☑	☑	☑	3	2	118*75.5*34			
		EM882S			☑	☑			20-80VDC	0.5-8.2A	5-24V		☑		☑	☑	☑	3	1	151*97*48	CABLE-PC		
DM-E		DM322E			☑				12-30VDC	0.3-2.2A	5V				☑	☑	☑	3	0	86*55*20			
		DM332E			☑				12-30VDC	1.0-3.2A	5V				☑	☑	☑	3	0	86*55*20			
		DM542E			☑				20-50VDC	1.0-4.2A	5V				☑	☑	☑	3	0	118*75.5*25.5			
		DM556E			☑				20-50VDC	1.7-5.6A	5V				☑	☑	☑	3	0	118*75.5*34			
		DM860E			☑	☑			20-80VDC	2.4-7.2A	5V				☑	☑	☑	3	0	151*97*42.5			
		DMA860E(V3.0)			☑	☑			18-80VAC 30-110VDC	2.4-7.2A	5V		☑	☑	☑	☑	☑	3	2	151*97*57	CABLE-PC-1	Standard ProTuner	
DM (Special)		DMA860H			☑	☑			18-80VAC 30-110VDC	2.4-7.2A	5V				☑	☑	☑	3	0	151*97*53			
		DMA882S			☑	☑			18-80VAC 30-110VDC	0.5-8.2A	5-24V		☑		☑	☑	☑	3	1	151*97*53	CABLE-PC	Standard ProTuner	
		DM1182	HS&CM Series			☑	☑			70-130VAC	0.5-8.2A	5V				☑	☑	☑	3	1	200*145*83	CABLE-PC	DMSeries ProTuner
		DM2282				☑	☑			180-240VAC	0.5-8.2A	5V				☑	☑	☑	3	1	200*145*83		
		3DM580S				☑	☑			20-50VDC	0.5-8.0A	5 / 24V		☑		☑	☑	☑	3	1	118*75.5*34	CABLE-PC-1	Standard ProTuner
		3DM883	3S Series			☑	☑			20-80VDC	2.2-8.3A	5 / 24V		☑	☑	☑	☑	☑	3	2	151*97*57		
DM-IO		DM422S-IO-24							12-40VDC	0.3-2.2A	24V		☑		☑	☑	☑	3	1	86*55*20	CABLE-PC-1	Standard ProTuner	
		DM556-IO							20-50VDC	0.5-5.6A	5 / 24V		☑		☑	☑	☑	3	2	118*75.5*34			
		DMA882S-IO							18-80VAC 30-110VDC	0.5-8.2A	5-24V		☑		☑	☑	☑	3	1	151*97*53	CABLE-PC		
		DM2282-IO-24							180-240VAC	0.5-8.2A	24V		☑		☑	☑	☑	3	1	200*145*83			
		DM456-V-24							20-40VDC	1.0-5.6A	24V				☑	☑	☑	3	1	118*75.5*34			
		DM480-V-24							20-80VDC	1.0-8.4A	24V				☑	☑	☑	3	1	118*75.5*34			
		DM805-AI			☑				0-5V Analog	20-80VDC	0.5-7.0A	5V				☑	☑	☑	4	1	118*75.5*34		CABLE-PC

■ Closed-loop Stepper drive quick selection table

☑ : Support ☐ : Not Support

Series	Picture	Model	Matched Motor Series	Control Type				Electrical Parameters				Motion Function Features					I/O		Encoder Resolution(ppr)	Others				
				EtherCAT	RS485 Modbus	Step&Dir	CW&CCW	Power Voltage	Output Current	Logical Voltage	Alarm Output	Brake Output	Self Test	Alarm Reset	Z Signal	Open/Closed Loop Selection	Digital Input	Digital Output		Mechanical Size (mm)	Tuning Cable	Tuning Software		
CS3E		CS3E-D503	CS-M	☑				20-50VDC	0.3-3.0A	5-24V			☑	☑		☑	☑	☑	7	7	1000/2500/5000	130*90.4*34	CABLE-MUSB1M5	Leadshine MotionStudio
		CS3E-D507		☑				20-50VDC	0.5-7.0A	5-24V			☑	☑		☑	☑	☑	7	7	130*90.4*34			
		CS3E-D1008		☑				18-80VAC 30-110VDC	0.5-8.0A	12-24V			☑	☑		☑	☑	☑	7	7	1000/5000	151*113*40		
		CS3E-D503E		☑				20-50VDC	0.3-3.0A	12-24V			☑	☑	☑	☑	☑	☑	6	2	118*90*34			
		CS3E-D507E		☑	☑			20-50VDC	0.5-7.0A	12-24V			☑	☑	☑	☑	☑	☑	6	2	118*90*34			
CS2RS		CS2RS-D503			☑				20-50VDC	0.3-3.0A	12-24V			☑	☑		☑	☑	7	3	1000/2500/5000	118*79.5*25.5	CABLE-PC-1	Leadshine MotionStudio
		CS2RS-D507			☑				20-50VDC	0.5-7.0A	12-24V			☑	☑		☑	☑	7	3	118*79.5*25.5			
		CS2RS-D1008						18-80VAC 30-110VDC	0.5-8.0A	12-24V			☑	☑		☑	☑	7	3	1000/5000	151*97*53			
CS1		CS1-D503S				☑	☑		20-50VDC	0.3-3.0A	5 / 24V			☑	☑	☑	☑	☑	4	6	1000/2500/5000	118*79.5*25.5	CABLE-PC	ProTuner CS_V3.0
		CS1-D507S				☑	☑		20-50VDC	0.5-7.0A	5 / 24V			☑	☑	☑	☑	☑	4	6	118*79.5*25.5			
CS		CS-D403			☑	☑		20-50VDC	0.3-3.0A	5V			☑	☑		☑	☑	3	1	1000/5000	116*69.2*26.5	CABLE-PC	ProTuner CS_V3.0	
		CS-D508			☑	☑		20-50VDC	0.5-7.0A	5V			☑	☑		☑	☑	3	1	116*69.2*26.5				
		CS-D808			☑	☑		20-80VDC	0.5-8.0A	5V			☑	☑		☑	☑	3	1	151*97*53				
		CS-D1008			☑	☑		18-80VAC 30-110VDC	0.5-8.0A	5V			☑	☑		☑	☑	3	1	151*97*53				
		CS-D508E			☑	☑		20-50VDC	0.5-7.0A	5 / 24V			☑	☑		☑	☑	3	2	1000/2500/5000	116*69.2*26.5	CABLE-PC-1	Leadshine MotionStudio	
		CS-D1008E			☑	☑		18-80VAC 30-110VDC	0.5-8.0A	5 / 24V			☑	☑		☑	☑	3	2	1000/5000	151*97*53			
ES2		ES2-D508			☑	☑		20-50VDC	0.5-8.0A	5-24V			☑	☑	☑	☑	☑	3	5	1000/2500/5000	125*99*44	CABLE-ACH1000	Standard ProTuner	
		ES2-DA808			☑	☑		40-80VAC	0.5-8.0A	5 / 24V			☑	☑	☑	☑	☑	6	5	1000/5000	157.5*130*54		CSES2 Series_setup	
		ES2-DA1208			☑	☑		90-130VAC	0.5-8.0A	5-24V			☑	☑	☑	☑	☑	3	5	180*140*70	Standard ProTuner			
		ES2-3DA2306	EM2-M			☑	☑		150-240VAC	0.5-8.0A	5-24V			☑	☑	☑	☑	☑	3	5	180*140*70			

CONTENTS

Stepper Products

Part Numbers	-----	12
EM3E Series Network Stepper Drives	-----	13
EM-CAN Series CANopen Stepper Drives	-----	14
EM2RS Series RS485 Modbus Stepper Drives	-----	15
Pulse Control Stepper Drives	-----	16
DM Series Special Type Stepper Drives	-----	19
CM Series Stepper Motors	-----	21

Closed Loop Stepper Products

Part Numbers	-----	33
CS3E Series EtherCAT Closed Loop Stepper Drives	-----	34
CS2RS Series Modbus Closed Loop Stepper Drives	-----	35
CS1 Series Pulse Control Closed Loop Stepper Drives	-----	36
CS Series Pulse Control Closed Loop Stepper Drives	-----	37
ES2 Series Vector Control Closed Loop Stepper Drives	-----	38
CS-M Series Closed Loop Stepper Motors	-----	39

Integrated Stepper Motors

Integrated Stepper Motors	-----	46
---------------------------	-------	----

Other Products

LSP Series Power Supplies	-----	49
PLF Series Gearboxes	-----	50

Stepper Products

Stepper Product Part Numbers

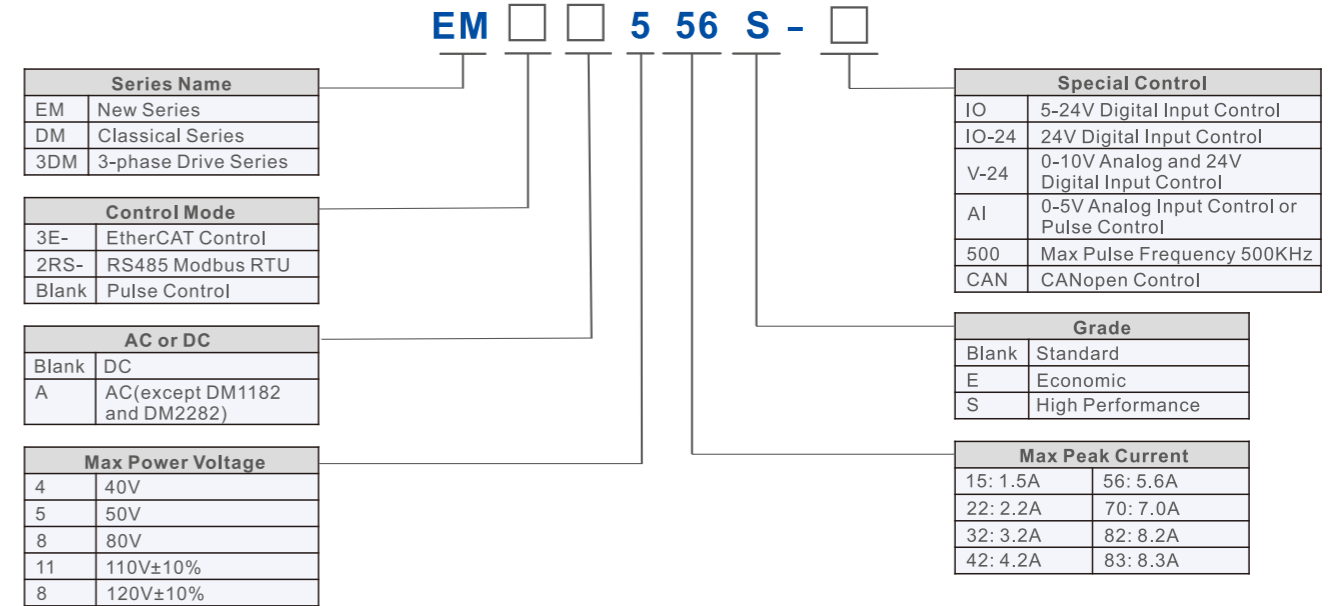

CM Stepper Motor

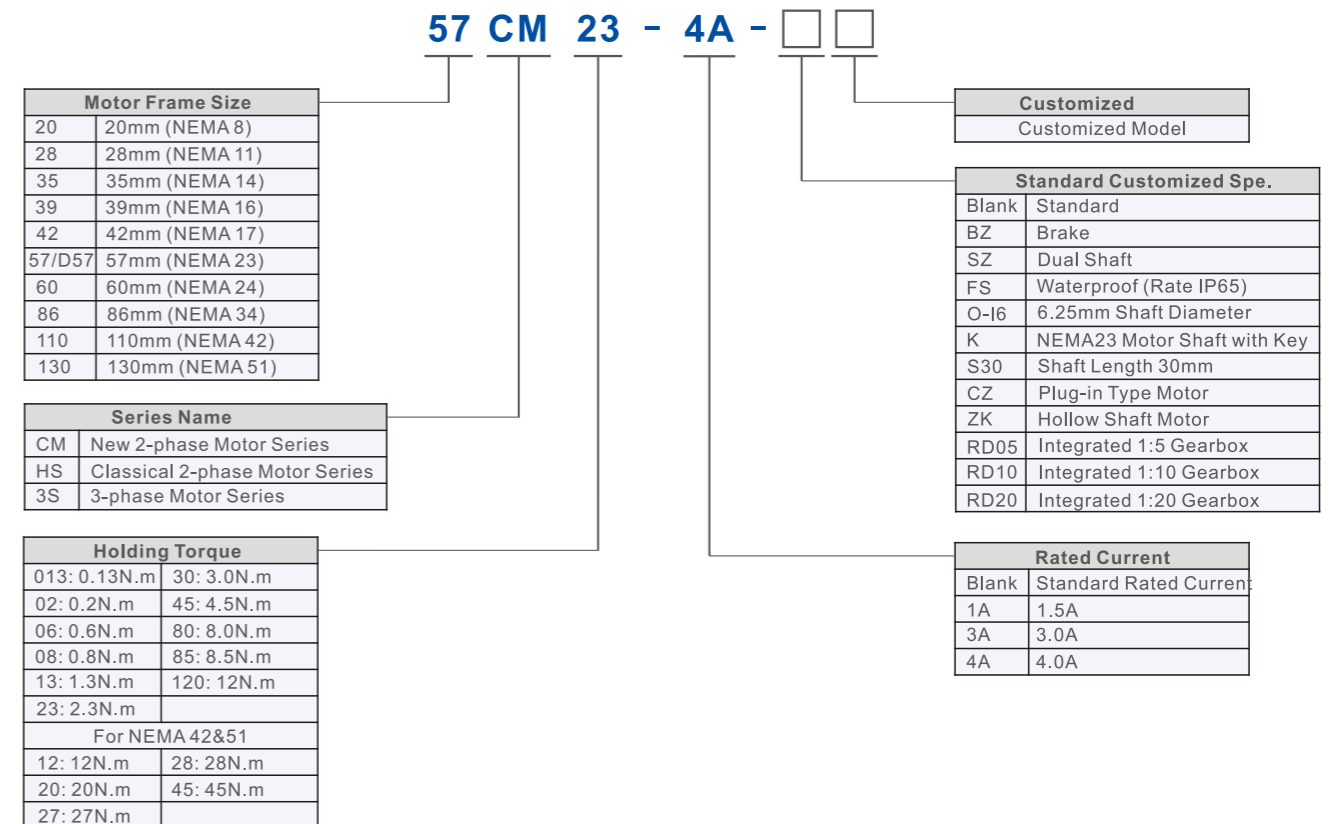

Network Stepper Drives

EM3E Series



- Support CoE control and CiA 402 protocol
- Matching most of master controller
- Conformance tested by ETG

■ Introduction

EM3E series drives support operating modes: Profile Position (PP), Profile Velocity (PV), Homing(HM) , Cyclic Synchronous Position (CSP). The products can be matched with most of EtherCAT controller/PLC such as Beckhoff, Omron, Trio, etc.

■ Features

- ▶ Low noise and vibration, smooth motion
- ▶ EM3E support standard EtherCAT with operation modes of PP, PV, CSP, HM
- ▶ Configurable I/O features: limit switch, alarm, brake, etc
- ▶ Optically coupled isolated input, strong anti-interference ability
- ▶ Auto-tuning of motor parameters
- ▶ Protections for over voltage, over current etc.



- Enhanced communication rate
- Flexible network topology
- Strong anti-interference ability
- High Cost-effective

Models	Operating Voltage	Output Current(A)	Matching Motor	Weight(Kg)	Size(mm)
EM3E-522E	20-50VDC	0.3-2.2	NEMA8/11/14/17	0.57	118*90.4*34
EM3E-556E	20-50VDC	2.1-5.6	NEMA17/23/24	0.57	118*90.4*34
EM3E-870E	20-80VDC	2.1-7.0	NEMA23/24/34	0.57	118*90.4*34
EM3E-A882	20-80VAC or 30-100VDC	2.1-8.0	NEMA34	0.85	118*90.4*34
CABLE-MUSB1M5	Tuning Cable				
CABLE-TX*M*-BUS	Network Cable: 0.1m, 0.2m, 0.3m, 0.4m, 1m, 1.5m, 2m, 3m,5m,7m, 10m,15m, 20m				

CANopen Stepper Drives

EM-CAN Series



- Support CiA 301/402 protocol
- Matching most of master controller

■ Introduction

EM-CAN series drives support operating modes: Profile Position (PP), Profile Velocity (PV), Homing(HM).

They have excellent performance including enhanced reliability, super-low stepper noise, anti-resonance, low-speed ripple smoothing and remain 60% less cost than servo at least.

■ Features

- ▶ Low noise and vibration, smooth motion
- ▶ EM-CAN support operation modes of PP, PV, HM
- ▶ Configurable I/O features: limit, alarm, brake, etc
- ▶ Optically coupled isolated input, strong anti-interference ability
- ▶ Auto-tuning of motor parameters
- ▶ Protections for over voltage, over current etc.

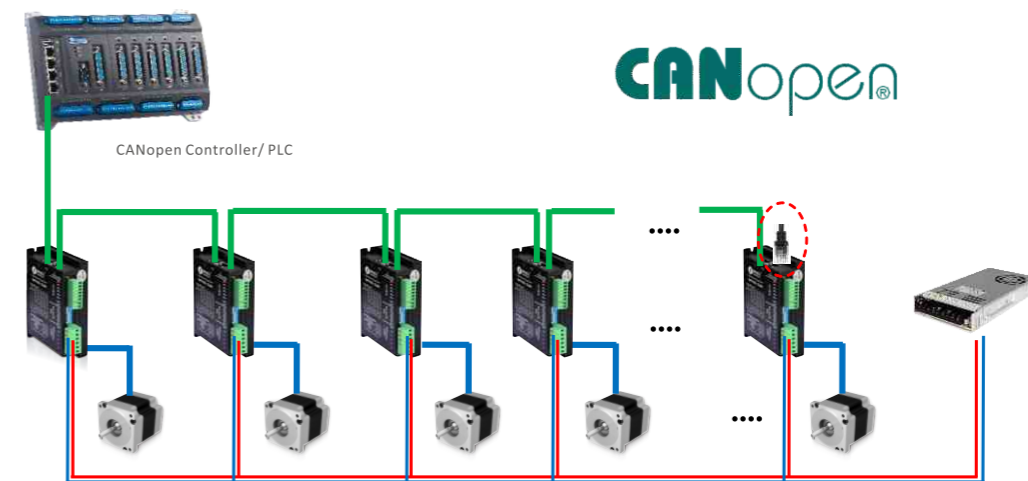

Models	Operating Voltage	Output Current(A)	Matching Motor	Weight(Kg)	Size(mm)
EM522-CAN	20-50VDC	0.3-2.2	NEMA8/11/14/17	0.28	118*75.5*33
EM556-CAN	20-50VDC	0.5-5.6	NEMA17/23/24	0.28	118*75.5*33
DMA882-CAN	20-80VAC or 30-100VDC	0.5-8.0	NEMA23/24/34	0.85	151*97*48
Terminal Resistance	The last node needs to add the terminal resistance generally				
CABLE-TX*M*-BUS	Network Cable: 0.1m, 0.2m, 0.3m, 0.4m, 1m, 1.5m, 2m, 3m,5m,7m, 10m,15m, 20m				
CAN to USB Converter	Not necessary, need to order this converter if using Leadshine Protuner				

RS485 Modbus Stepper Drives EM2RS Series



- Standard Isolated RS485 Modbus
- Smooth motion & Anti-resonance
- Built-in Uni-axial Control Instruction
- HMI, PLC or External I/O start motion

Features

- 7 Programmable Inputs
 - Limit + / - or Origin inputs
 - Quick stop, Alarm reset and Enable inputs
 - JOG + / - or Position Table inputs
- 3 Programmable Outputs
 - Alarm, Brake outputs
 - Homing / Instruction / Path complete
- Modes of Operation
 - Velocity
 - Position
 - Homing
- Support Functions
 - Teaching
 - Interrupt
 - Skip, Suspend, Circulate motion
- PC Software for Easy Setup, Fine Tune
- Matching Motors:
 - NEMA8, 11, 17, 23, 24, 34
 - Standard, dual shaft, brake, waterproof

1.Support RS485 communication

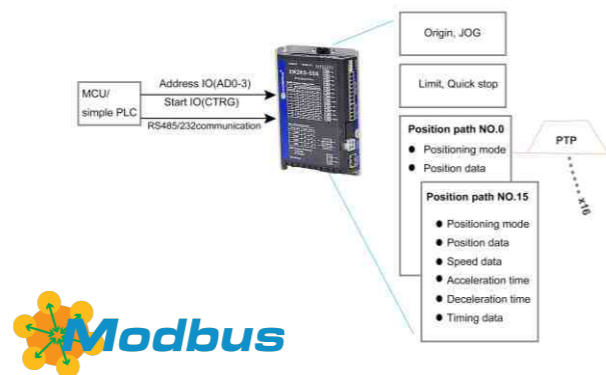
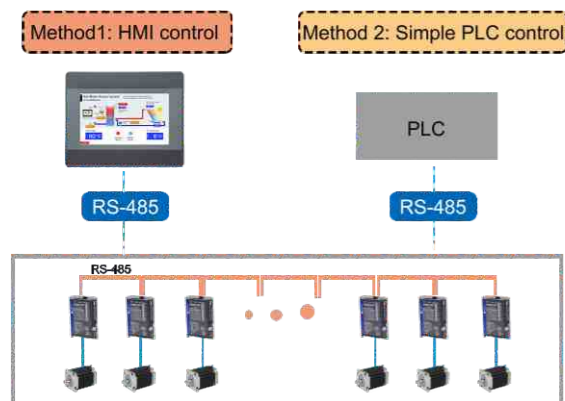

Models	Operating Voltage	Output Current(A)	Matching Motor	Weight(Kg)	Size(mm)
EM2RS-522	20-50VDC	0.3-2.2	NEMA8/11/14/17	0.55	118*79.5*25.5
EM2RS-556	20-50VDC	0.5-5.6	NEMA17/23/24	0.55	118*79.5*25.5
EM2RS-870	20-80VDC	0.5-7.0	NEMA23/24/34	0.55	118*79.5*25.5
CABLE-PC-1	Tuning Cable				
CABLE-TX*M*-BUS	Network Cable: 0.1m, 0.2m, 0.3m, 0.4m, 1m, 1.5m, 2m, 3m,5m,7m, 10m,15m, 20m				

Pulse Control Stepper Drives



- EM-S---Enhanced Version
- DM-E---Cost-effective Version

EM-S Series----Enhanced Performance

EM-S series stepper drives from Leadshine offer superior performance and exceptional high reliability. Based on Leadshine's 20+ years' experience in stepper motor control, they adopt the latest control technology and are ideal for modern machine manufactures. Not only inheriting features of smooth motion, low noise, low heating, etc. from past Leadshine stepper drives, they also offer new functions and features such as improved torque in all speed ranges, fault output, brake control, pulse command smoothing... They are capable of power wide range of stepper motors of NEMA 8, 11, 15, 17, 23, 34, and 42.

Features

- Torque increased by 10%-25%
- Step & DIR or CW & CCW control
- Alarm and Brake outputs
- 200KHz (500KHz optional) max frequency
- 5V or 24V signal voltage optional
- Soft-start with no "jump"
- Over-voltage, over-current

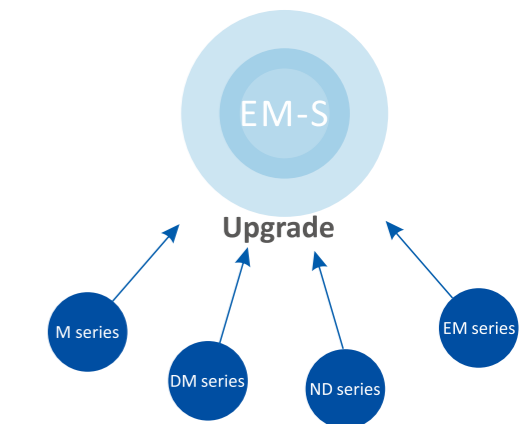

Torque comparison (same condition)

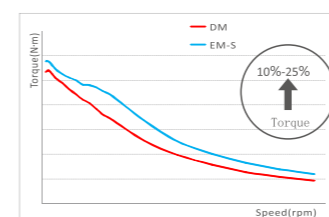

Pulse Smoothing Filter

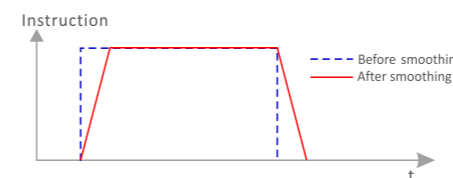

Features of Second DIP Switch

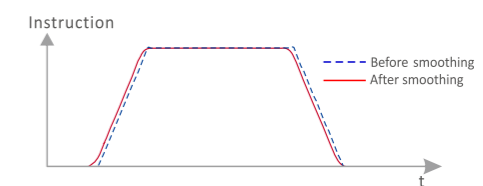
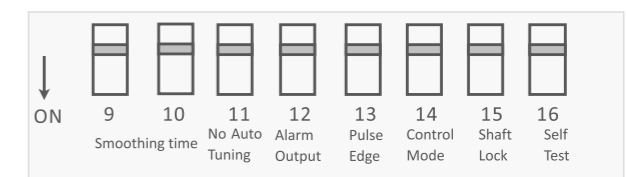

Alarm and Brake Outputs

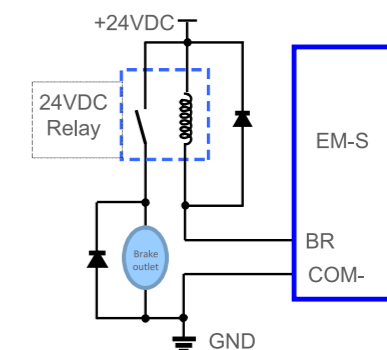
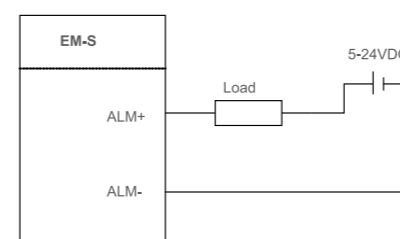

EM-S Series Electrical Specifications

Items	EM415S		EM422S		EM542S		EM556S		EM870S		EM882S	
	Min	Max	Min	Max	Min	Max	Min	Max	Min	Max	Min	Max
Output Current (A)	0.3	1.5	0.3	2.2	0.5	4.2	0.5	4.2	0.5	7.0	0.5	8.2
Power Voltage (VDC)	12	40	12	40	20	50	20	50	20	80	20	80
Max Input Frequency (KHz)	-	70	-	70	-	200	-	200 or 500*	-	200	-	200 or 500*
Logical Current (mA)	7	16	7	16	7	16	7	16	7	16	7	16
Logical Voltage (VDC)	0	5	0	5	0	5 or 24	0	5 or 24	0	5 or 24	0	5
Min Pulse Width (us)	7.5		7.5		2.5		2.5 or 1		2.5		2.5 or 1	
Matched Motors Size	NEMA8/11/14/17		NEMA17		NEMA17/23		NEMA23/24		NEMA23/24/34		NEMA34	

Note: (*) The drive with 500KHz is another model.

EM-S Series Connector and Mechanical Specifications

(unit: mm, 1 inch=25.4 mm)

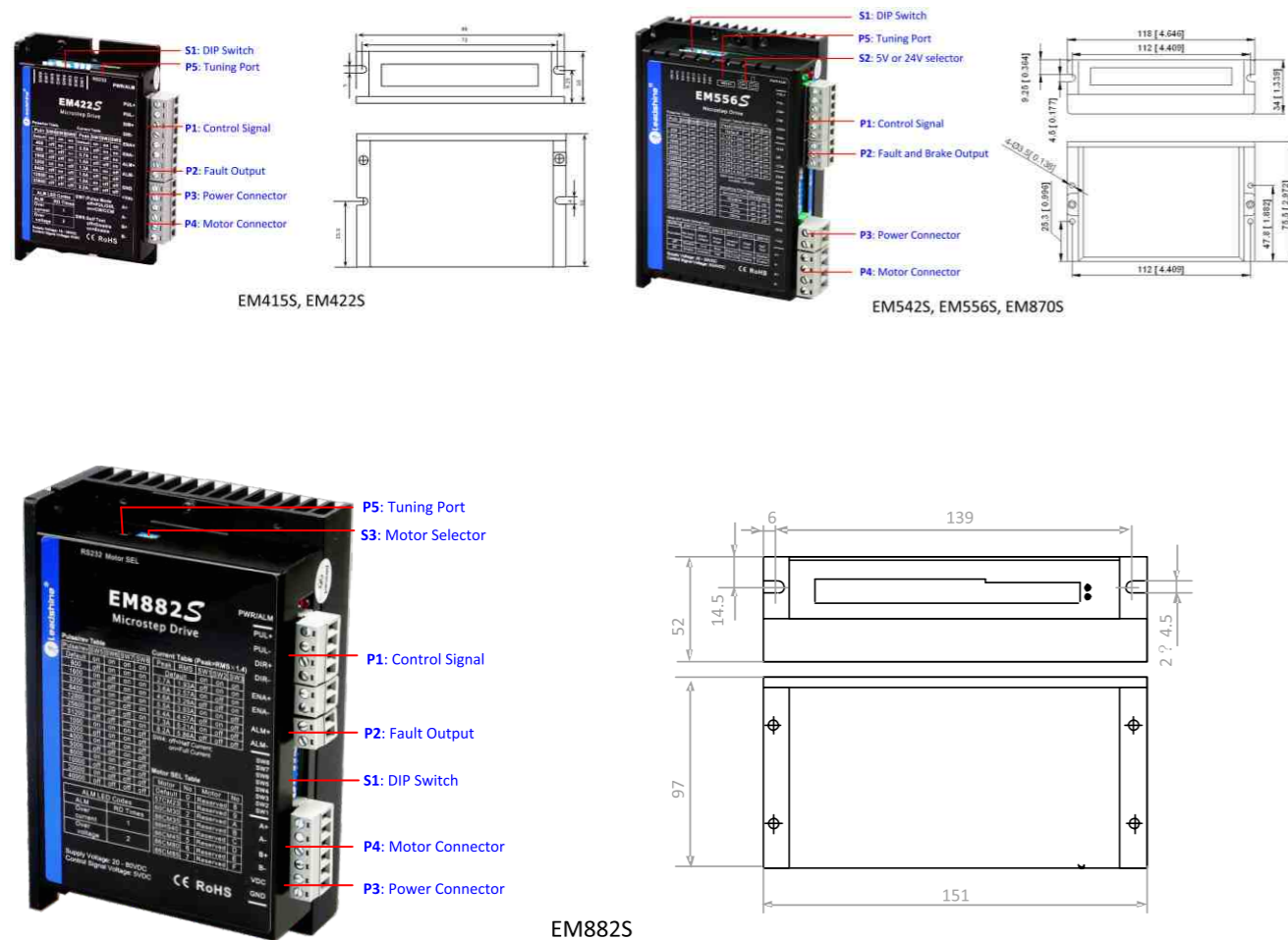

DM-E Series----Cost-effective

The DM-E series consists of stepper drives adopting Leadshine latest advanced stepper control technology. Those stepper drives are highly reliable with good performance and highly competitive cost. They can power a wide range of stepper motors from NEMA 8 to NEMA 34 (model dependent). DM-E stepper drives are easy to configure and setup. Output current and micro step resolution can be simply set up via DIP switches.



DM322E	DM332E	DM542E	DM556E	DM860E	DMA860E
12-30 VDC	12-30 VDC	20-50 VDC	20-50 VDC	20-80 VDC	20-80 VAC/ 30-110 VDC
0.3-2.2 A	1.0-3.2 A	1.0-4.2 A	1.7-5.6 A	2.4-7.2 A	2.4-7.2 A

DM-E Series Mechanical Specifications

(unit: mm, 1 inch=25.4 mm)

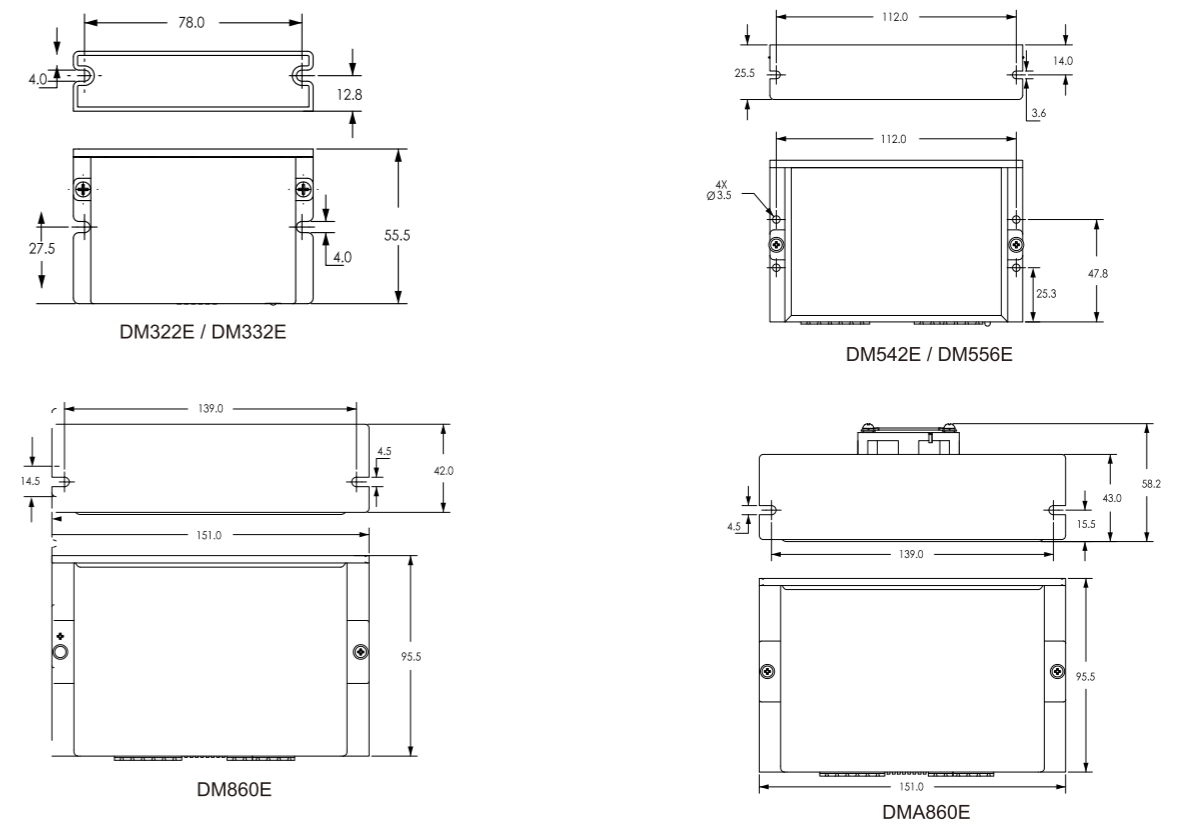

Special Type Stepper Drives



- DM Series: AC Input or 3-phase Type
- DM-IO Series: I/O digital control
- MX Series: 3-Axis or 4-Axis

DM Series---AC Power Input or 3-phase Type

Model	Phase	Power Voltage	Output Current(A)	Control Type	Logical Voltage(VDC)	Mechanical Size(mm)	Matched Motor Size
DMA860H	2	20-80 VAC or 30-110 VDC	2.4-7.2	Step&Dir, CW&CCW	5	151*97*48	NEMA23/24/34
DMA882S	2	20-80 VAC or 30-110 VDC	0.5-8.2	Step&Dir, CW&CCW	5	151*97*48	NEMA23/24/34
DM1182	2	70-130 VAC	0.5-8.2	Step&Dir, CW&CCW	5	202*167*63	NEMA34/42
DM2282	2	180-240 VAC	0.5-8.2	Step&Dir, CW&CCW	5	202*167*63	NEMA34/42/53
3DM580S	3	20-50 VDC	0.5-8.0	Step&Dir, CW&CCW	5	118*76*33	NEMA17/23/24/34
3DM883	3	20-80 VDC	2.2-8.3	Step&Dir, CW&CCW	5	151*97*48	NEMA24/34
3DM2283	3	180-240 VAC	2.2-11.7	Step&Dir, CW&CCW	5	202*167*63	NEMA 34/42/53

■ Mechanical specification (unit: mm, 1 inch=25.4 mm)

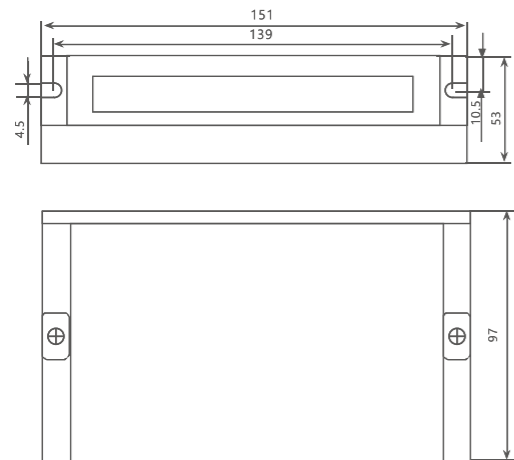

(a) Mechanical specifications of the DMA882S

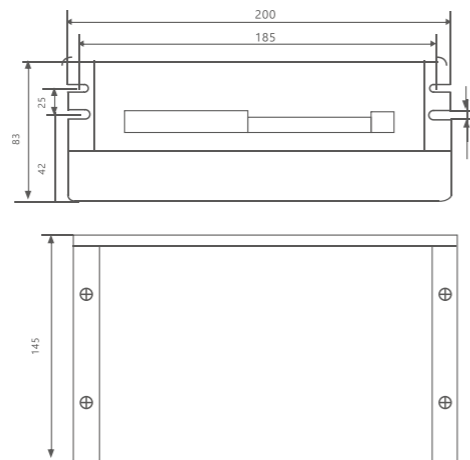

(b) Mechanical specifications of the DM1182

DM-IO Series---Digital / Analog Input Control Type

- ▶ External digital or analog input control
- ▶ Speed control by DIP switches
- ▶ PUL+ and PUL- signals indicate Start and Stop
- ▶ DIR+ and DIR- signals indicate motor running direction
- ▶ Easy to use in speed control applications, save controller/PLC

Model	DM442S-IO-24	DM556-IO	DMA882S-IO	DM2282-IO-24	DM456-V-24 / DM480-V-24	DM805-AI
Power Voltage	18-36 VDC	20-50 VDC	20-80 VDC or 30-110 VDC	130-240 VDC	20-40 VDC	20-80 VDC
Output Current(A)	0.3-2.2	0.5-5.6	0.5-8.2	0.5-8.2	0.5-5.6 / 0.5-8.4	0.5-7.0
Matched Motor Size	NEMA8/11/17	NEMA17/23/24	NEMA 23/24/34	110 / 130	NEMA17/23/24	NEMA17/23/24/34
Control Type	2-segment speed				0-10V analog, can be connected to 2 motors	0-5V analog Step&Dir
Logical Voltage	24V	5 / 24V	5-24V	24V	24V	5V
Tuning Port	Yes				/	Yes
Tuning Software	StandardProTuner				/	DM Series
Size	78*55*25	118*76*33	151*97*48	202*167*63	118*75.5*34	118*76*33

■ DM-IO series connectors

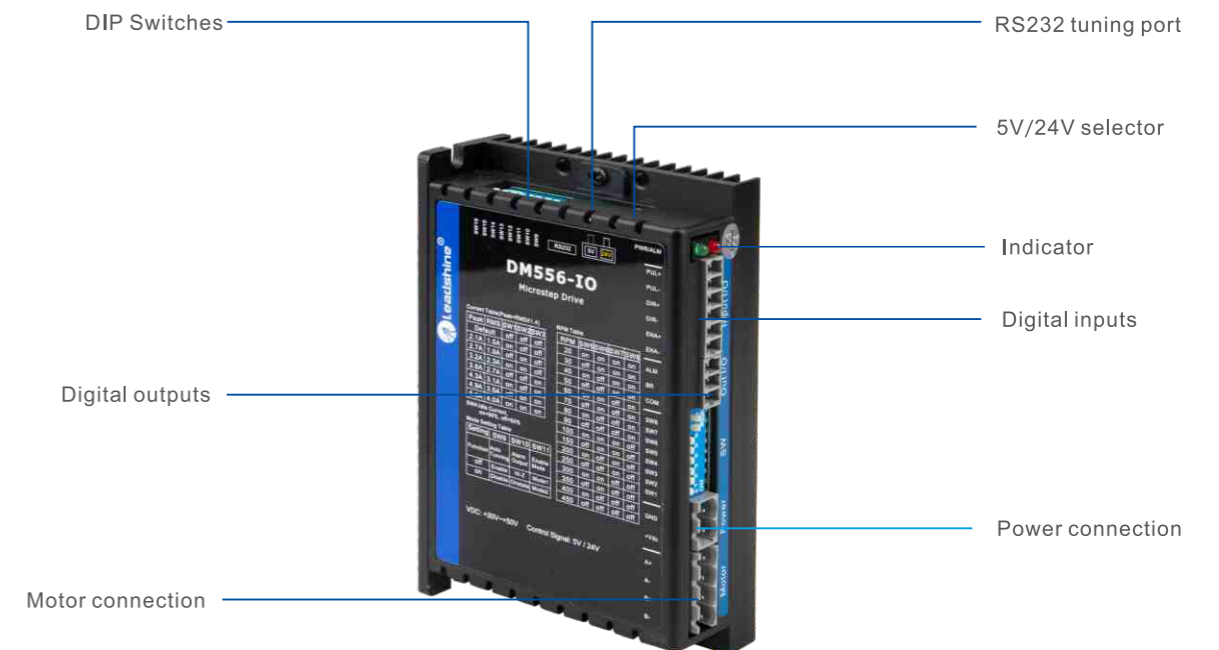

■ Applications

- ▶ Feeding and conveying devices in automation equipment
- ▶ Replacing some AC motors for smoother movement at low-medium speeds, save cost and mounting size.

Stepper Motors

CM Series

- Replace HS series stepper motors
- Frame size of NEMA8 to 42
- High reliability, Low motor heating, noise and vibration
- Multiple phase current optional for the same motor



Introduction

By implementing latest design and advanced manufacturing technologies, Leadshine offers hybrid stepper motors in wide frame sizes 8, 11, 14, 16, 17, 23, 24, 34, and 42. Those stepper motors are made of premium quality materials. Compared with ordinary stepper motors on the market. Those stepper motors outperforms in many aspects such as higher torque in all speed ranges, higher precision, lower heating, and lower vibration. Due to the implementation of highly automated manufacturing process and rigid quality assurance control, Leadshine CM series stepper motors are highly reliable with high product consistency.

High Torque:

Latest design for compact size but high torque

Smooth Motion:

Core components from global leading suppliers.

Low Heating:

Use of high quality silicon steel to ensure low motor heating.

High Consistency:

Highly automated manufacturing process and rigid quality control.

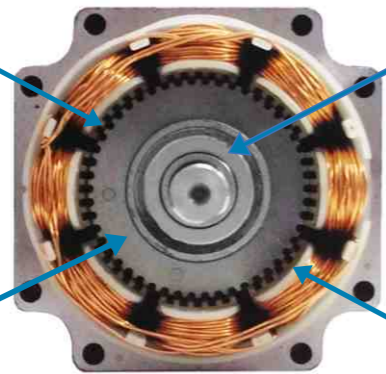

Leadshine CM series stepper motors are available in the following options:

- Standard single shaft stepper motors.
- IP 65 waterproof stepper motors.
- Dual shaft stepper motors.
- Stepper motors with electromagnetic brakes.
- Stepper motors with planetary gearboxes.
- Stepper motors with encoders (also called closed loop stepper motors).
- Stepper motors with encoder, brake, and gearboxes.

Leadshine CM stepper motors have been widely implemented in many industrial applications such as CNC routers, laser cutters, plasmas, plotters, medical equipment, battery manufacturing product lines, textile machines, packaging machines, etc.



Stepper Motor with brake



CM Series Stepper Motor



Permanent magnet brake

Low noise
Quick response
Low heat

CM series waterproof stepper motor, compared with the standard type, the back cover is redesigned, the lead wire is changed to waterproof connector, new sealing material is added between the front & back cover and the body, the motor body is made a comprehensive waterproof treatment, the motor shaft is selected high quality oil seal, so that the motor IP rate is IP65. can be applied to all kinds of wet, water, outdoor, oil splashing occasions.



General Specifications

Step Angle	1.8°
Position Accuracy	±0.09°
Temp Rise(Max.)	Max. 85K
Operation Environment	Temperature: -10°C+50°C ; Humidity: 85% Max
Insulation Class	B
Insulation Resistance	MIN 100 MΩ, 500 V DC
Dielectric Strength	500 VAC, 1 min
Radial Play	0.025 mm Max. (Load 5N)
Axial Play	0.075 mm Max. (Load 10N)

Installation & Operation Conditions

Motor Size	NEMA17	NEMA23	NEMA24	NEMA34
Store Temperature	-10°C+50°C			
Store Humidity	85% Max.			
Operation Environment	Non-corrosive gas and dust; No direct contact with water, oil (except the waterproof type)			
Radial Load(N) (Distance to the flange 10mm)	30	75	90	300
Axial Load(N)	Less than motor weight			

Stepper Motor Overview

1. Below matched drive is default Step&Direction type, other control types of drive also can be matched;
2. 3-phase stepper motors still keep selling 3S series, others recommend CM series;
3. Contact Leadshine for other customized model such as inch shaft diameters, modified cable, etc.

Phase/ Series	Frame Size	Length(mm)	Model	Rate Current (A)	Holding Torque(N.m)	Matched Drives	Remark	
2- Phase/ CM	NEMA 8	33	20CM003	0.6	0.03	EM415S		
		45	20CM005	0.6	0.05	EM415S		
	NEMA 11	32	28CM006	1.2	0.06	EM415S		
		41	28CM010	1.2	0.1	EM415S		
		51	28CM013	1.2	0.13	EM415S		
	NEMA 14	31	35CM015	2.0	0.15	EM422S		
		47	35CM04	2.0	0.4	EM422S		
	NEMA 17	33	42CM02-1A	1.0	0.2	EM415S		
			42CM02	1.5	0.2	EM422S		
		40	42CM04-1A	1.0	0.4	EM415S		
			42CM04	1.5	0.4	EM422S		
		47	42CM06-1A	1.5	0.6	EM422S		
			42CM06	2.5	0.6	EM422S/EM542S	Performance in high-speed	
			42CM06-SZ	2.5	0.6	EM422S/EM542S	Motor with dual shaft	
		60	42CM08-1A	1.5	0.8	EM422S		
			42CM08	2.5	0.8	EM422S/EM542S	Performance in high-speed	
			42CM08-SZ	2.5	0.8	EM422S/EM542S	Motor with dual shaft	
		NEMA 23	41	57CM06	3.0	0.6	EM542S	
				57CM13-3A	3.0	1.3	EM542S	
	57CM13			4.0	1.3	EM556S	Performance in high-speed	
	56		57CM13-SZ	4.0	1.3	EM556S	Motor with dual shaft	
			96	57CM13-BZ	4.0	1.3	EM556S	Motor with brake
	65		57CM13-FS	4.0	1.3	EM556S	IP65 waterproof	
			76	57CM23-3A	3.0	2.3	EM542S	
				57CM23-4A	4.0	2.3	EM556S	
	57CM23			5.0	2.3	EM556S/EM870S	Performance in high-speed	
	116		57CM23-SZ	5.0	2.3	EM556S/EM870S	Motor with dual shaft	
			90	57CM23-BZ	5.0	2.3	EM556S/EM870S	Motor with brake
	84		57CM23-FS	5.0	2.3	EM556S/EM870S	Motor with waterproof	
		57CM26-4A	4.0	2.6	EM556S			
		57CM26	5.0	2.6	EM556S/EM870S	Performance in high-speed		
	67	57CM26-SZ	5.0	2.6	EM556S/EM870S	Motor with dual shaft		
		D57CM21-4A	4.0	2.1	EM556S			
		D57CM21	5.0	2.1	EM556S/EM870S	Performance in high-speed		
	88	D57CM21-SZ	5.0	2.1	EM556S/EM870S	Motor with dual shaft		
		D57CM31-4A	4.0	3.1	EM556S			
		D57CM31	5.0	3.1	EM556S/EM870S	Performance in high-speed		
			D57CM31-SZ	5.0	3.1	EM556S/EM870S	Motor with dual shaft	

Phase/Series	Frame Size	Length(mm)	Model	Rate Current (A)	Holding Torque(N.m)	Matched Drives	Remark	
2-Phase/ CM	NEMA 34	68	60CM22X	5.0	2.2	EM556S/EM870S	Motor with dual shaft	
			60CM22X-SZ	5.0	2.2	EM556S/EM870S	Motor with brake	
			60CM22X-BZ	5.0	2.2	EM556S/EM870S		
		86	60CM30X	5.0	3.0	EM556S/EM870S		
			60CM30X-SZ	5.0	3.0	EM556S/EM870S	Motor with dual shaft	
			60CM30X-BZ	5.0	3.0	EM556S/EM870S	Motor with brake	
		66	86CM35	4.0	3.5	EM556S/EM870S		
			80	86CM45	6.0	4.5	EM882S	
				86CM45-SZ	6.0	4.5	EM882S	Motor with dual shaft
		86CM45-BZ		6.0	4.5	EM882S	Motor with brake	
		86CM45-FS		6.0	4.5	EM882S	Motor with waterproof	
		98	86CM80	6.0	8.0	EM882S		
	118		86CM85	6.0	8.5	EM882S		
			86CM85-SZ	6.0	8.5	EM882S	Motor with dual shaft	
			86CM85-BZ	6.0	8.5	EM882S	Motor with brake	
			86CM85-FS	6.0	8.5	EM882S	Motor with waterproof	
	NEMA 42/ NEMA 51	129	86CM120	6.0	12	EM882S/DM1182		
		115	110CM12	6.0	12	DM2282		
150		110CM20	6.5	20	DM2282			
201		110CM28	6.0	28	DM2282			
283		130HS45	7.0	45	DM2282			
3-Phase/ 3S		NEMA 23	50	573S09	3.5	0.9	3DM580S	
	76		573S15	5.8	1.5	3DM580S		
	80		573S20-LS	5.8	1.5	3DM580S		
	NEMA 34	71	863S22	5.0	2.2	3ND883		
		103	863S42	5.0	4.2	3ND883		
		135	863S68H	2.3	6.8	3DM2283		

Standard Stepper Motor Specifications

NEMA 8 (20mm)



Standard Model:

Model	Length (mm)	Holding Torque(N.m)	Rate Current (A)	Resistance/Phase(Ω)	Inductance/Phase(mH)	Inertia (Kg.cm ²)	Matched Drives
20CM003	33	0.03	0.6	5.7	2.6	0.003	EM415S
20CM005	45	0.05	0.6	7	3.4	0.004	EM415S

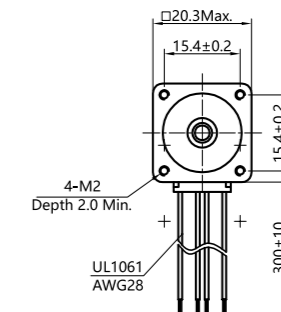
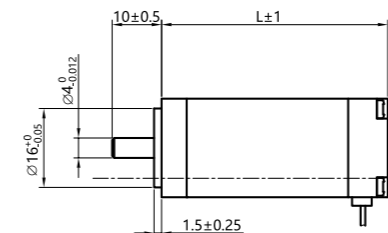

NEMA 11 (28mm)

Standard Models:



Model	Length (mm)	Holding Torque(N.m)	Rate Current (A)	Resistance/Phase(Ω)	Inductance/Phase(mH)	Inertia (Kg.cm ²)	Matched Drives
28CM006	32	0.06	1.2	1.4	1.0	0.009	EM415S
28CM010	41	0.1	1.2	1.8	1.6	0.013	EM415S
28CM013	51	0.13	1.2	2.2	2.3	0.018	EM415S

Unit: mm 1inch=25.4mm

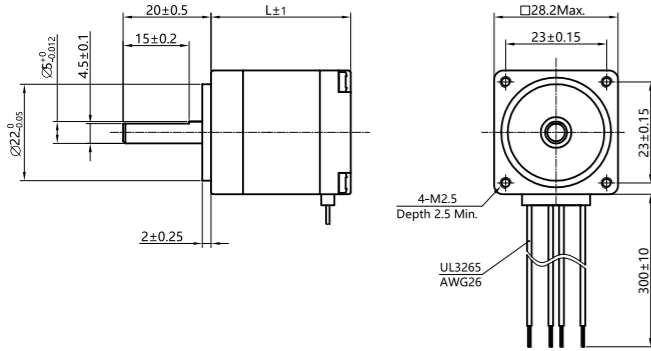

NEMA 14 (35mm)

Standard Models:



Model	Length (mm)	Holding Torque(N.m)	Rate Current (A)	Resistance/Phase(Ω)	Inductance/Phase(mH)	Inertia (Kg.cm ²)	Matching Drives
35CM015	31	0.15	2	0.8	1.3	0.019	EM422S
35CM04	47	0.36	2	1.2	1.9	0.026	EM422S

Unit: mm 1inch=25.4mm

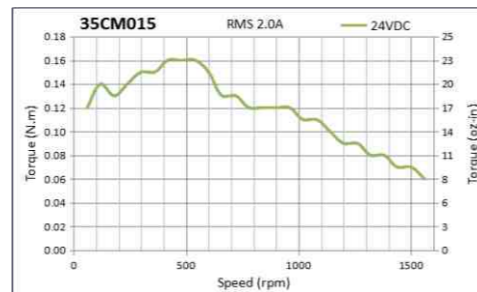
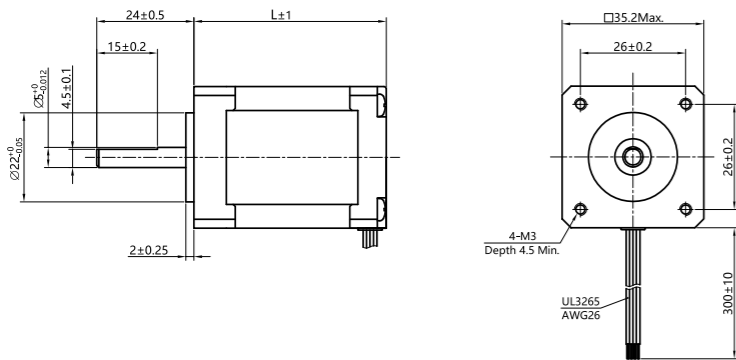

NEMA 17 (42mm)

Standard Models:



Model	Length (mm)	Holding Torque(N.m)	Rate Current (A)	Resistance/Phase(Ω)	Inductance/Phase(mH)	Inertia (Kg.cm ²)	Matching Drives
42CM02-1A	33	0.21	1	4.5	6.5	0.035	EM415S
42CM02		0.21	1.5	1.4	1.4	0.035	EM422S
42CM04-1A	40	0.4	1	4.0	7.9	0.054	EM415S
42CM04		0.4	1.5	2.3	4.3	0.054	EM422S
42CM06-1A	47	0.6	1.5	2.2	4.5	0.072	EM422S
42CM06		0.6	2.5	0.9	1.6	0.072	EM432S
42CM08-1A	60	0.8	1.5	3.0	6.9	0.110	EM422S
42CM08		0.8	2.5	1.0	2.4	0.110	EM542S

Unit: mm 1inch=25.4mm

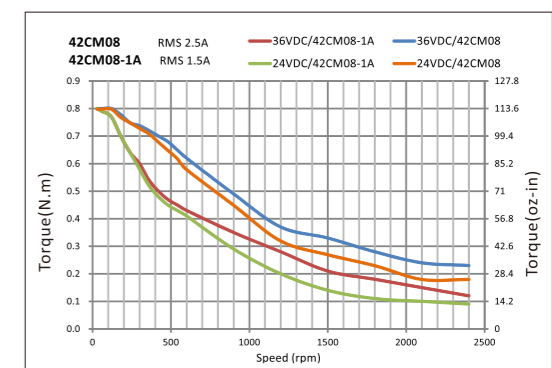
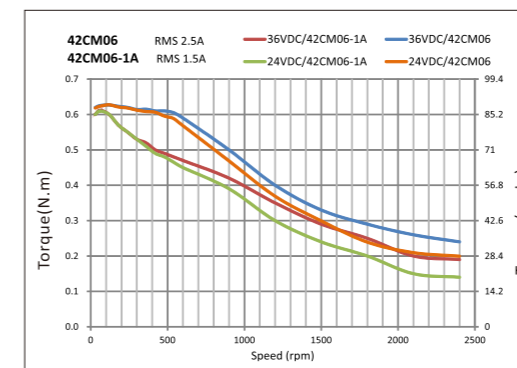
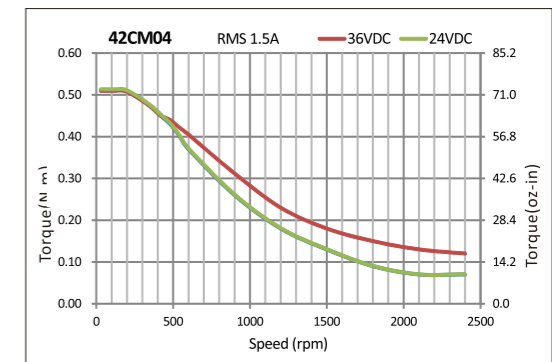
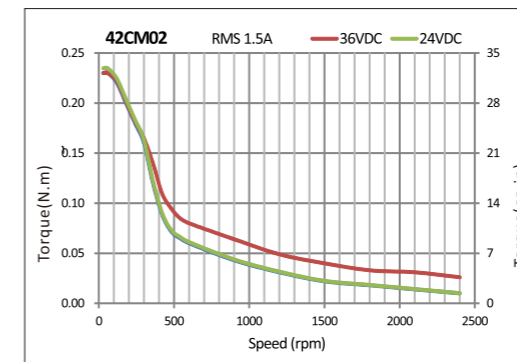
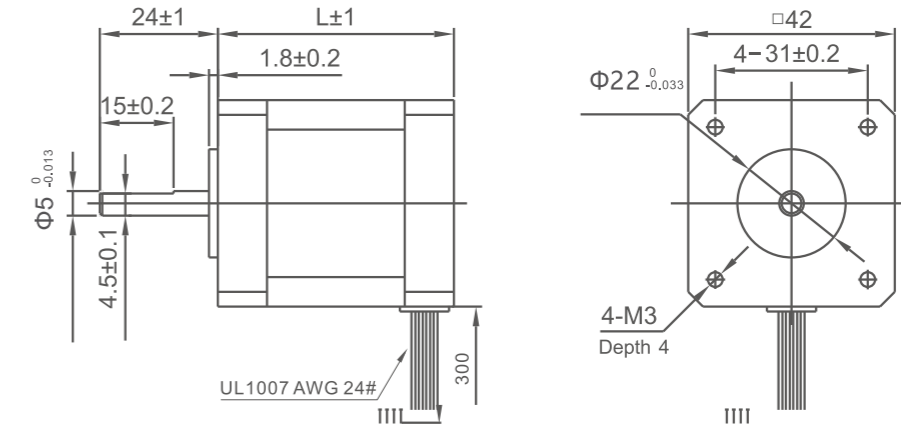

NEMA 23 (57mm)



Standard Models:

Model	Length (mm)	Holding Torque(N.m)	Rate Current (A)	Resistance/Phase(Ω)	Inductance/Phase(mH)	Detent Torque	Inertia (Kg.cm ²)	Matching Drives
57CM06	41	0.6	3	0.7	1.4	0.02	0.12	EM542S
57CM13-3A	55	1.3	3	0.8	2.8	0.04	0.3	EM542S
57CM13		1.3	4	0.42	1.6			EM542S/EM556S
57CM12X		1.2	4	0.6	1.4			EM542S/EM556S
57CM21X	76	2.1	4	0.6	2.4	0.07	0.48	EM542S/EM556S
57CM23-3A		2.1	3	1.1	4.2			EM542S
57CM23-4A	76	2.3	4	0.5	2	0.07	0.5	EM542S/EM556S
57CM23		2.3	5	0.38	1.75			EM556S
57CM22X	80	2.2	5	0.34	1.74	0.07	0.5	EM556S/EM870S
57CM26-4A	85	2.6	4	0.8	3.2	0.08	0.52	EM542S/EM556S
57CM26		2.6	5	0.44	2			EM556S/EM870S

Note: Motors with 1/4 in(6.35mm) shaft diameter are available.

Unit: mm 1inch=25.4mm

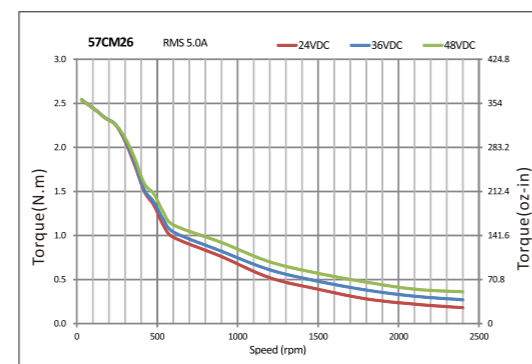
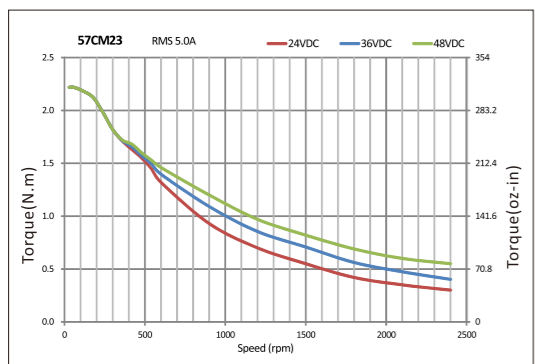
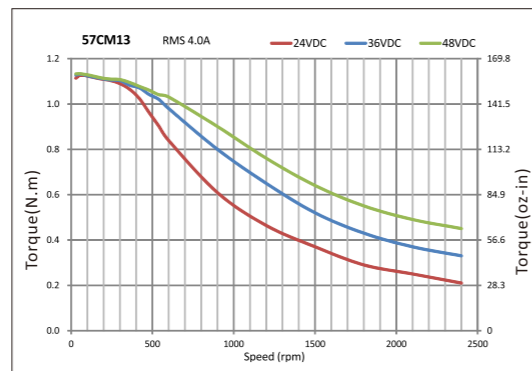
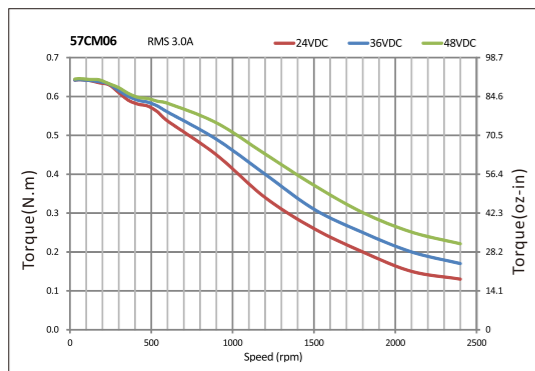
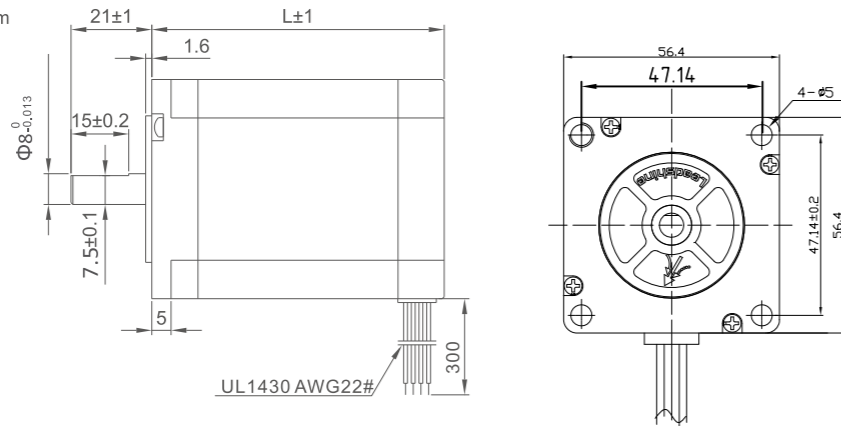

NEMA 23 (57mm)



Standard Models:

Model	Length (mm)	Holding Torque(N.m)	Rate Current (A)	Resistance/Phase(Ω)	Inductance/Phase(mH)	Detent Torque(N.m)	Inertia (Kg.cm ²)	Matching Drives
D57CM21-4A	67	2.1	4	0.5	1.77	0.09	0.57	EM556S
D57CM21		2.1	5	0.21	0.75			EM556S/EM870S
D57CM31-4A	88	3.1	4	0.62	2.8	0.10	0.84	EM556S
D57CM31		3.1	5	0.26	1.18			EM556S/EM870S

Unit: mm 1inch=25.4mm

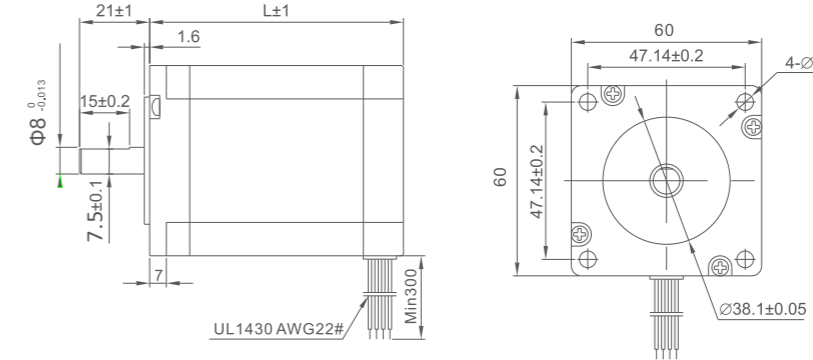

NEMA 24 (60mm)



Standard Models:

Model	Length (mm)	Holding Torque(N.m)	Rate Current (A)	Resistance/Phase(Ω)	Inductance/Phase(mH)	Detent Torque(N.m)	Inertia (Kg.cm ²)	Matching Drives
60CM22X	67	2.2	5	0.33	1.05	0.07	0.49	EM556S/EM870S
60CM30X	85	3.0	5	0.46	2.0	0.08	0.69	EM556S/EM870S

Unit: mm 1inch=25.4mm

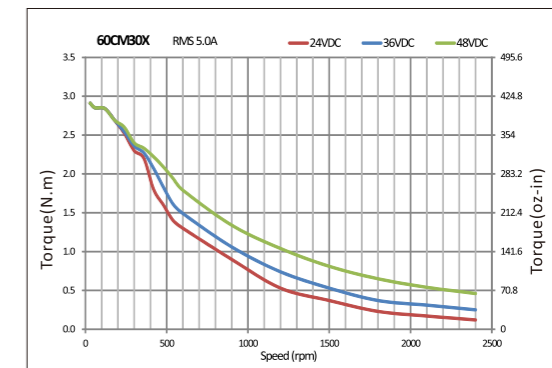
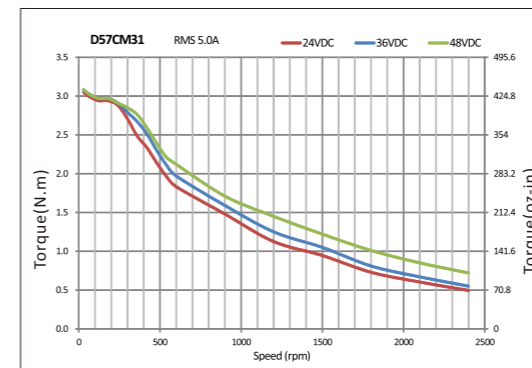
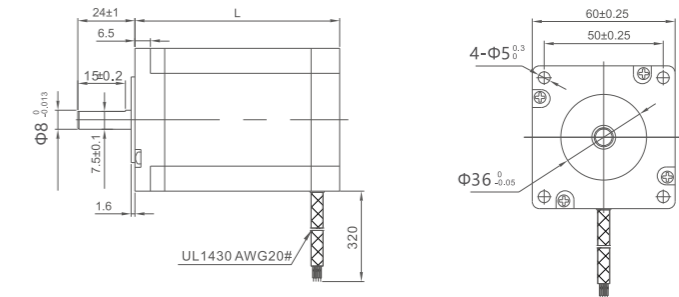

NEMA 34 (86mm)



Standard Models:

Model	Length (mm)	Holding Torque(N.m)	Rate Current (A)	Resistance/Phase(Ω)	Inductance/Phase(mH)	Inertia (Kg.cm ²)	Matching Drives
86CM35	65	3.5	4	0.42	2.67	1.00	EM556S/EM870S
86CM45	80	4.5	6	0.43	2.95	1.40	EM882S
86CM80	98	8.0	6	0.63	4.0	2.50	EM882S
86CM85	118	8.5	6	0.53	4.25	2.70	EM882S
86CM120	129	12.0	6	0.75	5.30	2.94	EM882S/DMA882S

Note: Motors with 14mm shaft diameter are available.

Unit: mm 1inch=25.4mm

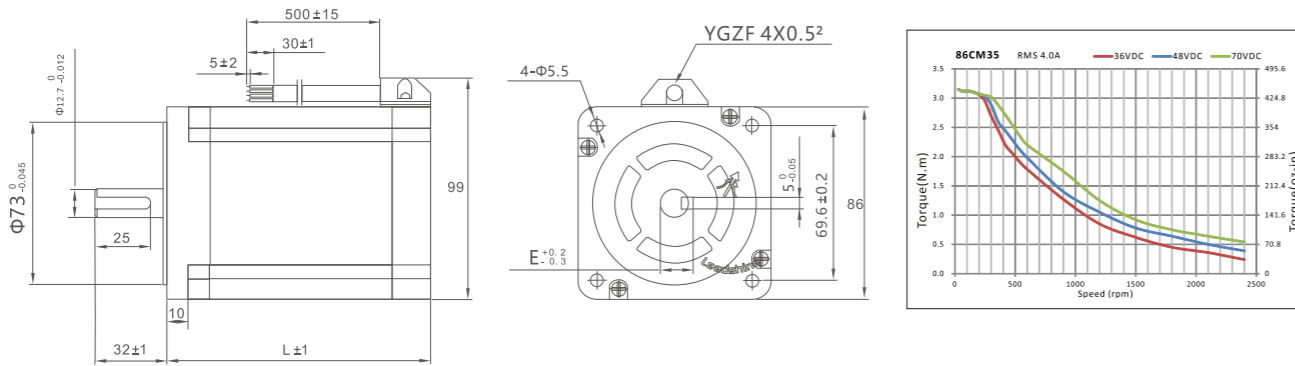

NEMA 42 & 51 (110mm & 130mm)

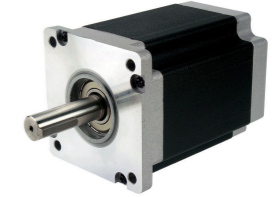

Standard Models:

Model	Length (mm)	Holding Torque(N.m)	Rate Current (A)	Resistance/Phase(Ω)	Inductance/Phase(mH)	Inertia (Kg.cm ²)	Matching Drives
110CM12	115	12	6	0.53	6.5	7.2	DM2282
110CM20	150	20	6	0.8	15	10.9	DM2282
110CM28	201	28	6.5	1.2	22	16.2	DM2282
130HS27	227	27	6	0.86	12.5	15.7	DM2282
130HS45	283	45	7	0.66	9.0	22.9	DM2282

Unit: mm 1inch=25.4mm

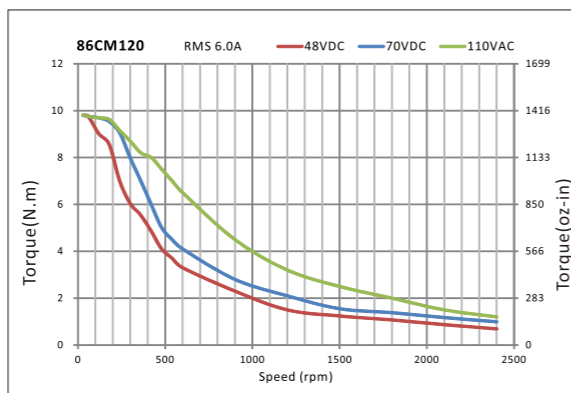
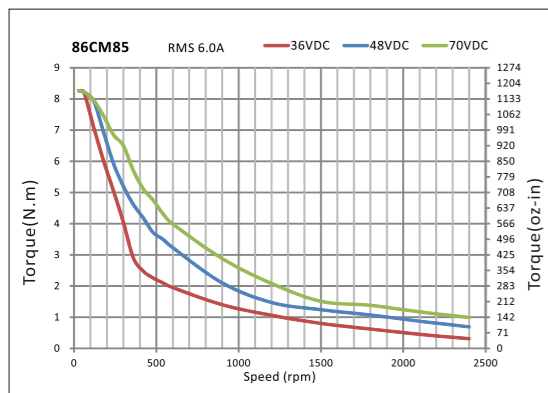
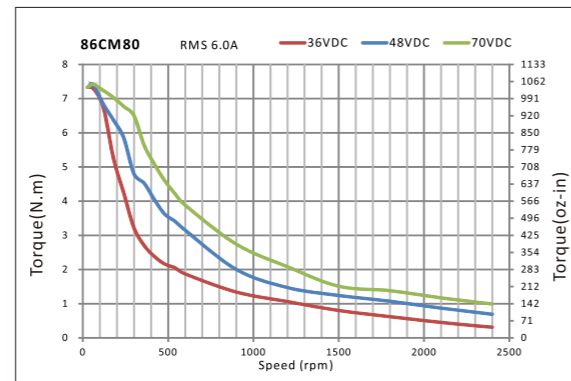
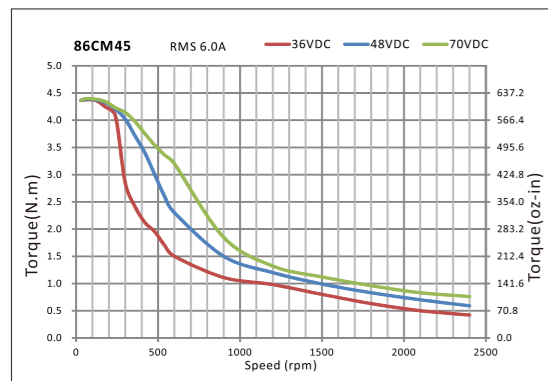
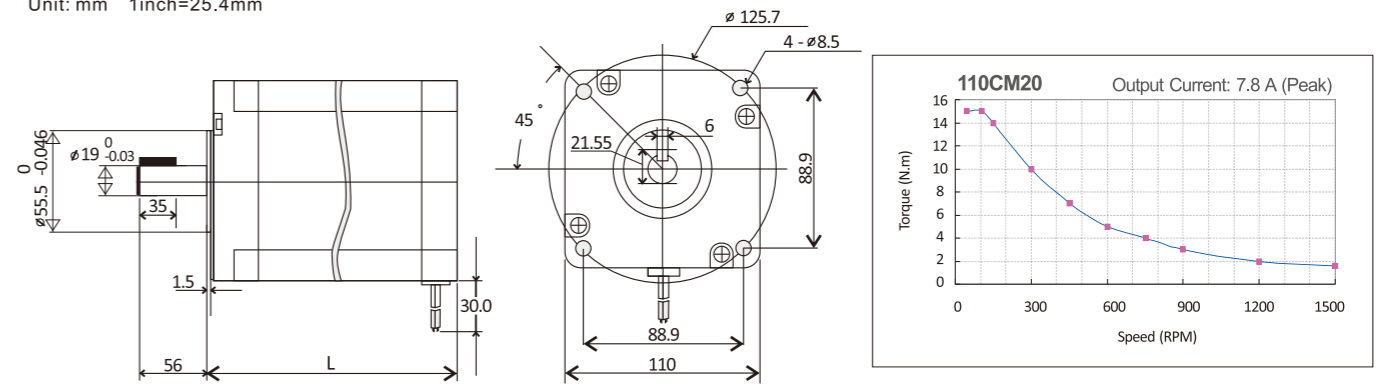

Unit: mm 1inch=25.4mm

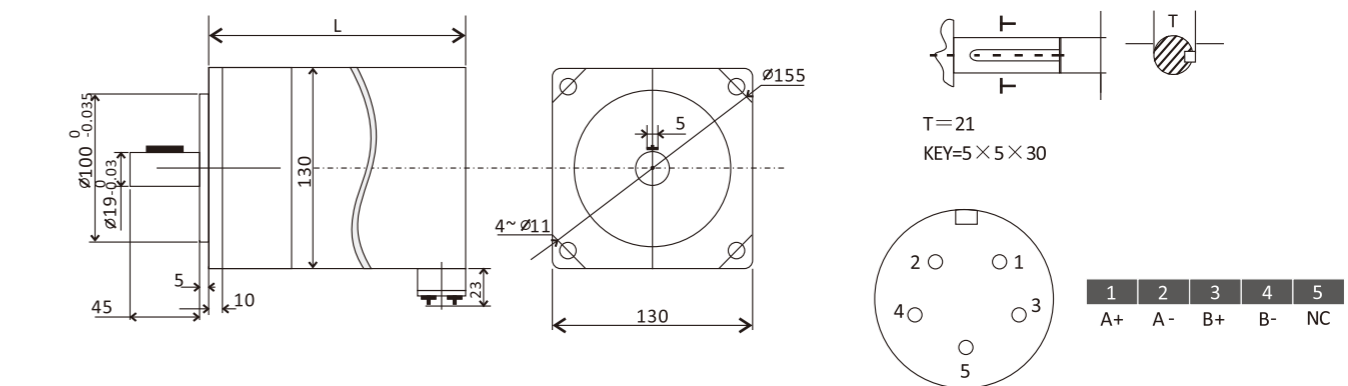

3-phase:NEMA 23, 34, 42

Standard Models:

Model	Length (mm)	Holding Torque(N.m)	Rate Current (A)	Resistance/Phase(Ω)	Inductance/Phase(mH)	Inertia (Kg.cm ²)	Matching Drives
573S09	50	0.9	3.5	0.77	1.8	1.00	3DM580S
573S15	76	1.3	5.8	0.86	2.0	1.40	3DM580S
863S22	71	2.3	5	0.9	2.8	2.50	3ND883
863S42	103	4.3	5	1.35	4.5	2.70	3ND883
863S68H	135	6.8	2.3	4.5	20	2.94	3DM2283

Unit: mm 1inch=25.4mm

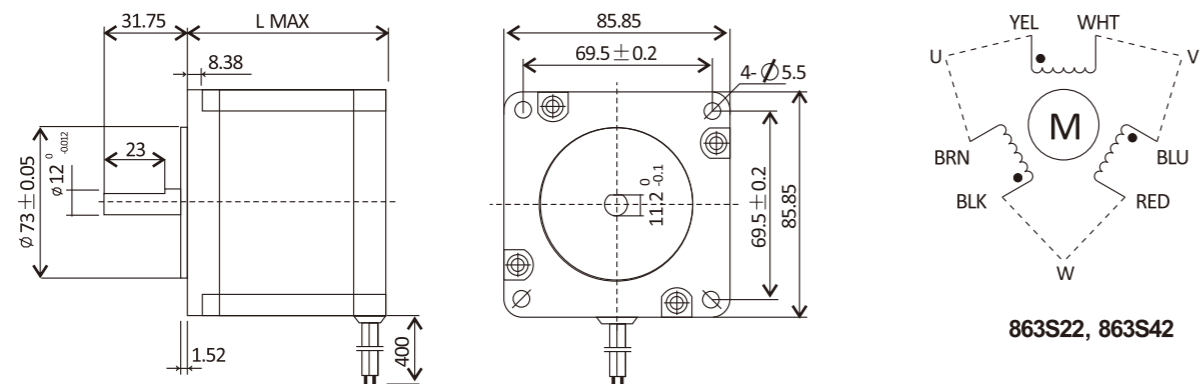
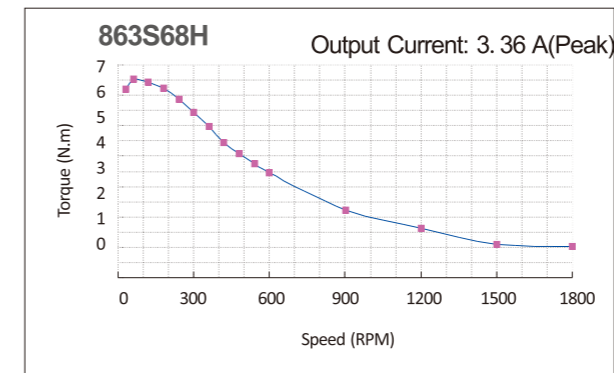
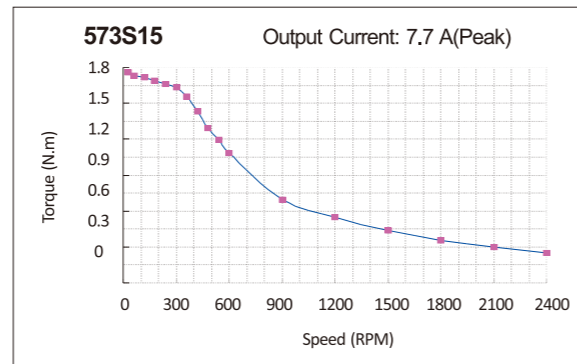
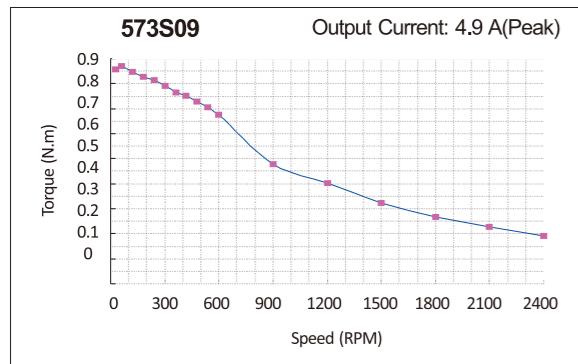
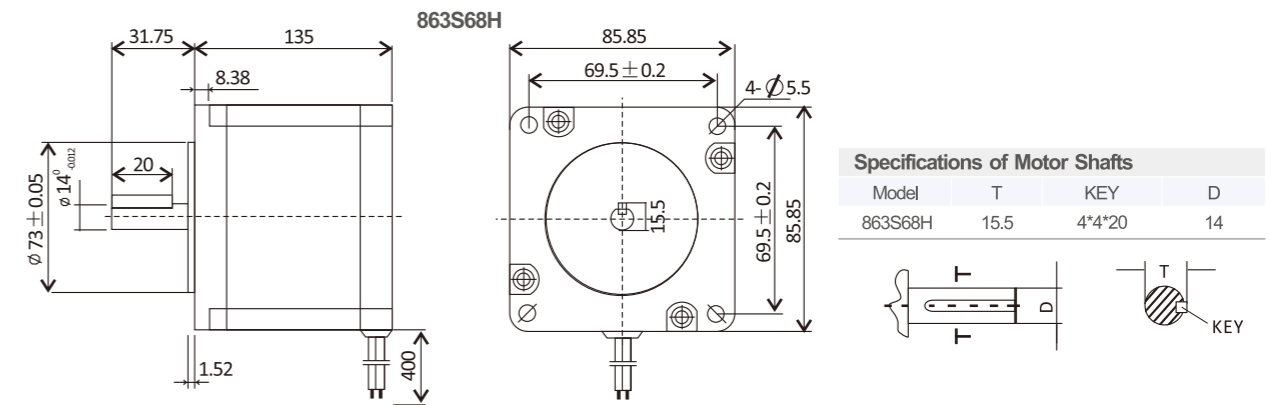
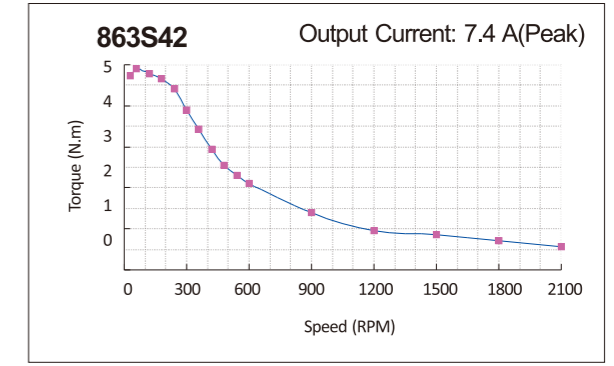
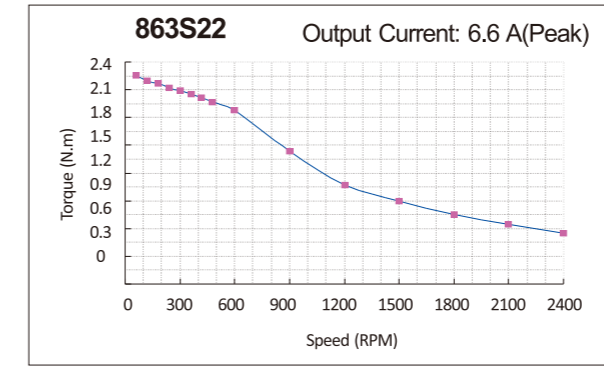
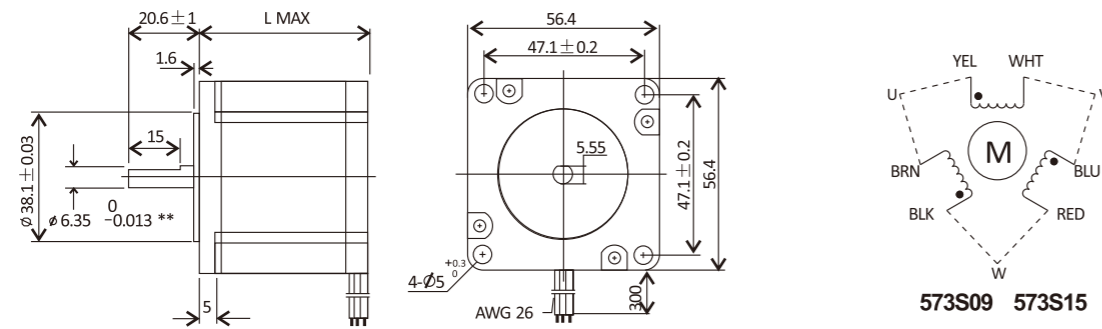

Closed Loop Stepper Products

Closed Loop Stepper Product Part Numbers

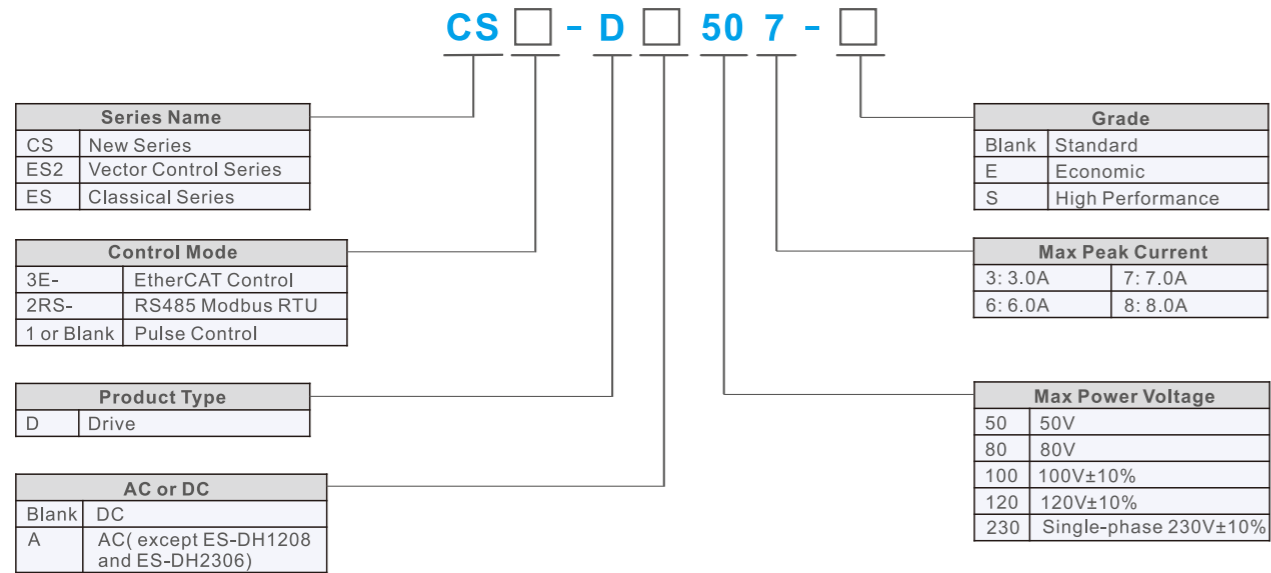

Closed Loop Stepper Motor

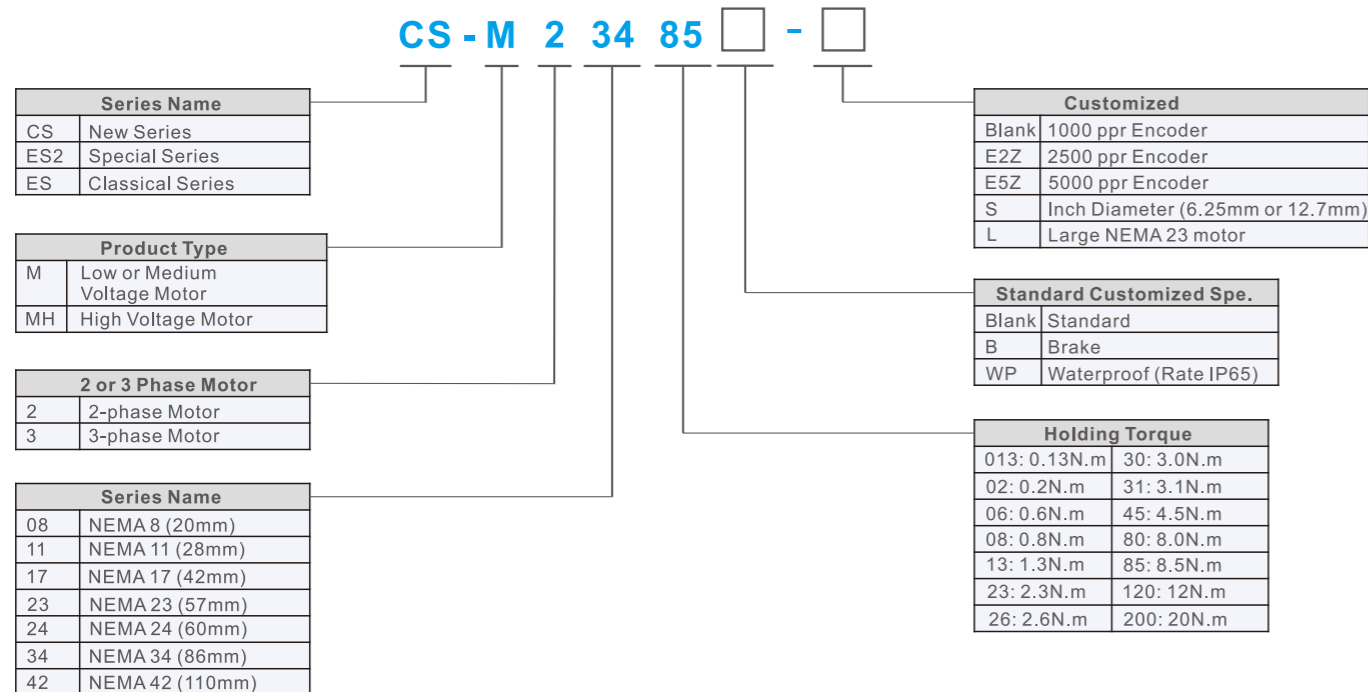

EtherCAT Closed Loop Stepper Drives CS3E Series



- Support CoE control and CiA 402 protocol
- Matching most of master controller
- Conformance tested by ETG
- No loss of step, Excellent performance

Introduction

The CS3E series drives support operating modes: Cyclic Synchronous Position (CSP), Profile Position (PP), Profile Velocity (PV), Homing(HM). The products can be matched with most of EtherCAT controller/PLC such as Beckhoff, Omron, Trio, etc. They have excellent performance including enhanced reliability, super-low noise, anti-resonance, low-speed ripple smoothing and remains 40% less cost than network servo at least. Can power 2-phase NEMA8,11, 14, 17, 23, 24 and 34 stepper motors with incremental encoder in many industrial applications such as CNC, medical, electronics, packaging...

Features

- No loss of step, No hunting, No torque reservation
- CS3E support standard EtherCAT protocol with operation modes of PP, PV, CSP, HM
- 7 configurable digital inputs, 7 optically isolated digital outputs include brake output
- USB port for parameters configuration
- Two 7-segment display velocity or slave ID or operation mode or error code
- Encoder resolution: 1000 / 5000 line for NEMA11/14/17/23/24/ 34 CS motors
- Protections for over-voltage, over-current and position following error, encoder wiring error, etc.



Models	Operating Voltage	Output Current(A)	Matching Motor	Weight(Kg)	Size(mm)
CS3E-D503	20-50VDC	0.5-3.0	NEMA8/11/14/17	0.28	116*69.2*26.5
CS3E-D507	20-50VDC	0.5-5.6	NEMA17/23/24	0.28	116*69.2*26.5
CS3E-D1008	20-80VAC or 30-110VDC	0.5-8.0	NEMA34	0.85	151*97*52
CABLE-MUSB1M5	Tuning Cable				
CABLE-TX*M*-BUS	Network Cable: 0.1m, 0.2m, 0.3m, 0.4m, 1m, 1.5m, 2m, 3m,5m,7m, 10m,15m, 20m				
CABLEM-BM*M*	Encoder Extension Cable				
CABLEM-RZ*M*	Motor Extension Cable				

Modbus Closed Loop Stepper Drives CS2RS Series



- Standard Isolated RS485 Modbus
- No loss of step & smooth motion
- Built-in Uni-axial Control Instruction
- HMI, PLC or External I/O start motion

■ Features

- ▶ 7 Programmable Inputs
 - Limit + / - or Origin inputs
 - Quick stop, Alarm reset and Enable inputs
 - JOG + / - or Position Table inputs
- ▶ 3 Programmable Outputs
 - Alarm, Brake outputs
 - Homing / Instruction / Path complete
- ▶ Modes of Operation
 - Velocity
 - Position
 - Homing
- ▶ Support Functions
 - Teaching
 - Interrupt
 - Skip, Suspend, Circulate motion
- ▶ PC Software for Easy Setup, Fine Tune
- ▶ Matching Motors:
 - NEMA8, 11, 17, 23, 24, 34
 - Standard, dual shaft, brake, waterproof

2. No Loss of step

Adopted closed loop step system to make real-time position error correction, can eliminate potential loss of step.

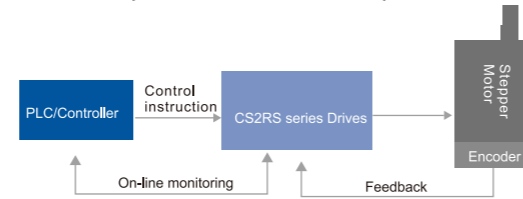

3. Built-in uni-axial control instruction

Programmable 16-segment position table, support positioning/homing/ limit/ quick stop/ JOG...



1. Support RS485 communication

Standard Modbus RTU protocol, RS485 communication can network up to 31 axes

- Method 1: HMI control
- Method 2: Simple PLC control

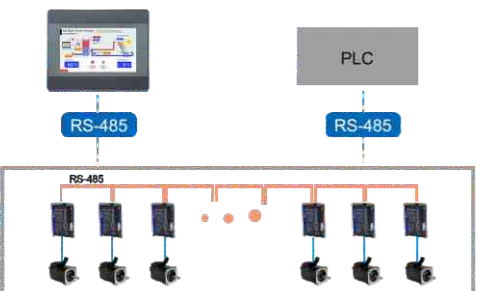

Models	Operating Voltage	Output Current(A)	Matching Motor	Weight(Kg)	Size(mm)
CS2RS-D503	20-50VDC	0.5-3.0	NEMA8/11/14/17	0.38	116*69.2*26.5
CS2RS-D507	20-50VDC	0.5-7.0	NEMA17/23/24	0.38	116*69.2*26.5
CS2RS-D1008	20-80VAC or 30-100VDC	0.5-8.0	NEMA24/34	0.57	151*97*53
CABLE-PC-1	Tuning Cable				
CABLEM-BM*M*	Encoder Extension Cable				
CABLEM-RZ*M*	Motor Extension Cable				

Pulse Control Closed Loop Stepper Drives

- CS1 Series---Enhanced Version
- CS Series---Cost-effective Version



CS1 Series---Enhanced Performance

■ Inputs and Outputs

- ▶ Step & DIR (CW & CCW) inputs
- ▶ Enable input and Error Reset input
- ▶ Alarm output and In Position output
- ▶ Brake outputs
- ▶ Encoder A/B/Z outputs

■ Switch Settings

- ▶ Microstep resolution
- ▶ Rotation direction
- ▶ Pulse Mode
- ▶ Positional command filter
- ▶ Closed / Open Loop Mode
- ▶ Encoder resolution
- ▶ Gain adjustment and output current
- ▶ 5V or 24V signal voltage optional

■ Connectors

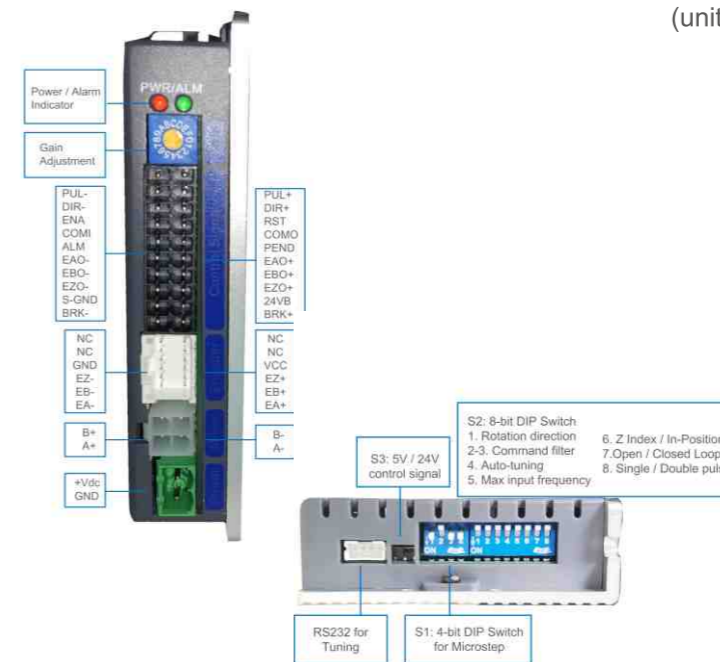

■ Electrical Specifications

Items	CS1-D503S		CS1-D507S	
	Min	Max	Min	Max
Output Current (A)	0.5	3	0.5	7
Power Voltage (VDC)	20	50	20	50
Input Frequency (KHz)	-	500	-	500
Input Signal Current(mA)	7	20	7	20
Output Signal Current(mA)	-	100	-	100

■ Mechanical Specifications



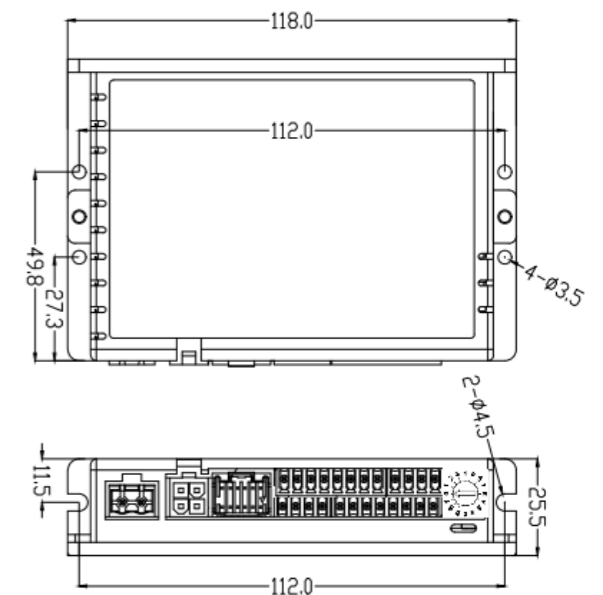

(unit: mm 1 inch=25.4mm)



CS Series----Cost-effective

The CS series consists of ES seasy servo drives adopting Leadshine latest advanced closed loop control technology. Those drives are highly reliable with good performance and highly competitive cost. They can power a wide range of closed loop stepper motors from NEMA 8 to NEMA 34 (model dependent) with incremental encoders. CS series drives are easy to configure and setup.

Electrical Specifications

CS Series Drives				
Model				
	CS-D403	CS-D508	CS-D808	CS-D1008
Operating Voltage	20-50VDC	20-50VDC	20-80VDC	20-80VAC or 30-110VDC
Peak Output Current	0.3-3.0A	0.5-7.0A	0.5-8.0A	
Control Signal Voltage	5-24V			
Max. Input Frequency	200KHz (500KHz optional)			

Mechanical Specifications

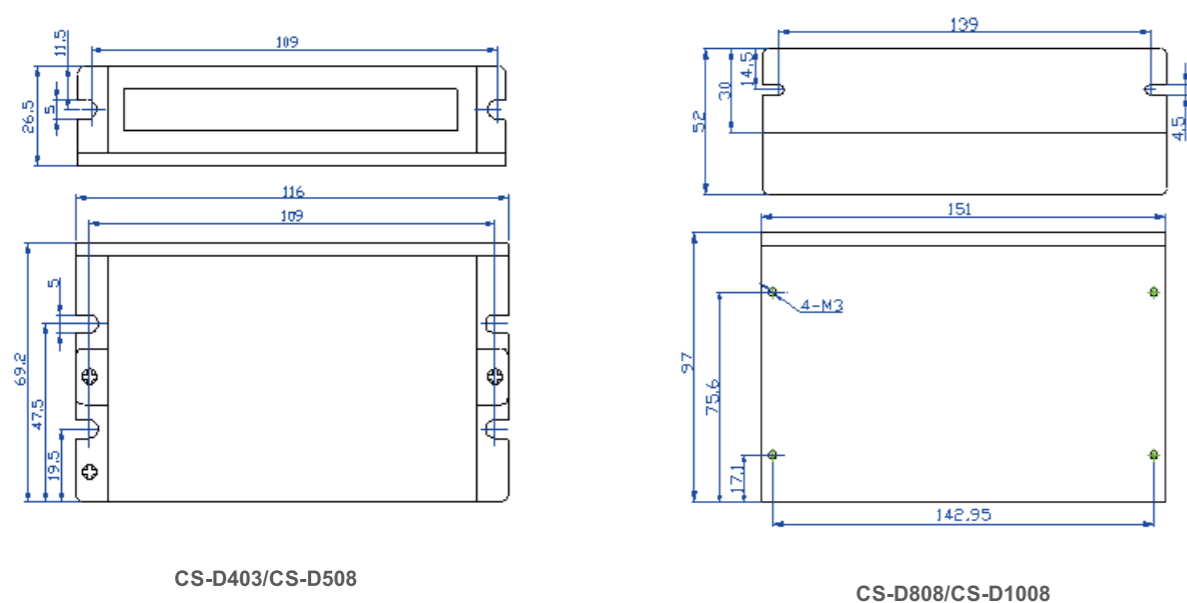

Vector Control Type ES2 Series

- Quicker Response
- Lower Heating
- Lower Noise



The ES2 series easy servos cleverly combined the advantages of AC servo and stepper motor, while it remains high cost-effective. It adopts the advanced vector control technology, using the internal encoder to close the position, velocity and current loops in real time. It guarantees close to and even better performance than AC servos in applications with less than 2500RPM speed at much lower prices, which can help to enhance the competitiveness of your equipment.

			
ES2-D508	ES2-DA808	ES2-DA1208	ES2-3DA2306
NEMA8,11,14,17,23,24 motor	NEMA34 motor	NEMA34 motor	NEMA34,NEMA42 motor
50VDC, 8A	70VAC, 8A	110VAC, 8A	220VAC, 6A

Mechanical Specifications

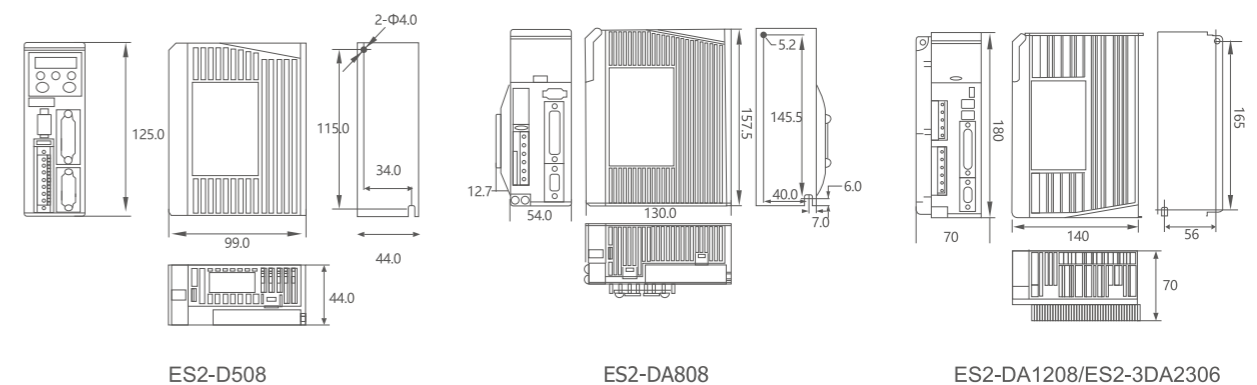

Closed Loop Stepper Motors

CS-M Series

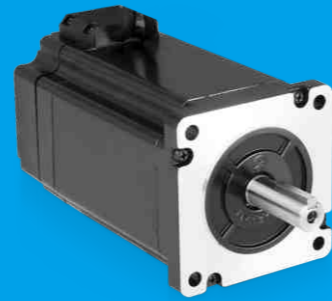

- Replace ES-M series easy servo motor
- Frame size of NEMA 8 to 34
- High reliability and high precision
- Reliable encoder solution

Introduction

CS-M series closed loop stepper motor integrated the CM series stepper motor and encoder, which can provide large torque, low heat and reliable position feedback signals. CS-M series also includes the types with brake, waterproof and different resolution. As a result of large-scale automated production lines and strict quality management system, CS-M series motors are more stable, reliable, superior, consistent and has a lower lost. [Most of ES-M easy servo motors will be replaced by CS-M motors.](#)

Encoder Specifications

Encoder Resolution	1000 ppr, 2500 ppr, 5000 ppr
Encoder Current	Typical 56mA /Max. 59mA
Low Level	0.4v@20mA Max
High Level	2.4v@-20mA Min

Motor Specifications

Step Angle	1.8°
Position Accuracy	±0.09°
Temp Rise(Max.)	Max. 85K
Operation Environment	Temperature: -10°C+50°C ; Humidity: 85% Max
Insulation Class	B
Insulation Resistance	MIN 100 MΩ, 500 V DC
Dielectric Strength	500 VAC, 1 min
Radial Play	0.025 mm Max. (Load 5N)
Axial Play	0.075 mm Max. (Load 10N)

Installation & Operation Conditions

Motor Size	NEMA17	NEMA23	NEMA24	NEMA34
Store Temperature	-10°C+50°C			
Store Humidity	85% Max.			
Operation Environment	Non-corrosive gas and dust; No direct contact with water, oil (except the waterproof type)			
Radial Load(N) (Distance to the flange 10mm)	30	75	90	300
Axial Load(N)	Less than motor weight			

Closed Loop Stepper Motor Overview

1. Below matched drives are Pulse Control type, EtherCAT and Modbus RS485 types are also available;
2. 3-phase high voltage closed loop stepper motors are ES2-MH series, others are CS-M series;
3. Contact Leadshine for other model such as NEMA 8 to NEMA14 motors, inch shaft diameter, etc.

Phase/ Series	Frame Size	Length(mm)	Model	Holding Torque(N.m)	Matching Drives	Remark
2-phase/ CS-M	NEMA 17	56	CS-M21702	0.2	CS1-D503S	
		63	CS-M21704	0.4	CS1-D503S	This motor is not recommended
		70	CS-M21706	0.6	CS1-D503S	
		83	CS-M21708	0.8	CS1-D503S	
	NEMA 23	60	CS-M22306	0.6	CS1-D507S	
		75	CS-M22313	1.3	CS1-D507S	Replace ES-M22310
		109	CS-M22313B	1.3	CS1-D507S	Motor with brake
		94	CS-M22313WP	1.3	CS1-D507S	Motor with waterproof
		95	CS-M22323	2.3	CS1-D507S	Replace ES-M22320
		131	CS-M22323B	2.3	CS1-D507S	Motor with brake
		115	CS-M22323WP	2.3	CS1-D507S	Motor with waterproof
		103	CS-M22326	2.6	CS1-D507S	
		86	CS-M22321-L	2.1	CS1-D507S	NEMA23 motor with large body
		105	CS-M22331-L	3.1	CS1-D507S	NEMA23 motor with large body
	NEMA 24	89	CS-M22422	2.2	CS1-D507S	
		129	CS-M22422B	2.2	CS1-D507S	Motor with brake
		113	CS-M22422WP	2.2	CS1-D507S	Motor with waterproof
		107	CS-M22430	3.0	CS1-D507S	
		143	CS-M22430B	3.0	CS1-D507S	Motor with brake
		130	CS-M22430WP	3.0	CS1-D507S	Motor with waterproof
		95	CS-M23435	3.5	CS-D808	
		109	CS-M23445	4.5	CS-D808	
		134	CS-M23445B	4.5	CS-D808	Motor with brake
		115	CS-M23445WP	4.5	CS-D808	Motor with waterproof
	NEMA 34	127	CS-M23480	8.0	CS-D808	
		152	CS-M23480B	8.0	CS-D808	Motor with brake
		133	CS-M23480WP	8.0	CS-D808	Motor with waterproof
		147	CS-M23485	8.5	CS-D808/ES2-DA1208	
		172	CS-M23485B	8.5	CS-D808/ES2-DA1208	Motor with brake
		153	CS-M23485WP	8.5	CS-D808/ES2-DA1208	Motor with waterproof
158		CS-M234120	12	CS-D808/ES2-DA1208		
183		CS-M234120B	12	CS-D808/ES2-DA1208	Motor with brake	
164		CS-M234120WP	12	CS-D808/ES2-DA1208	Motor with waterproof	
3-phase/ ES2-MH		NEMA 34	157	ES2-MH33480	8.0	ES2-3DA2306
	190		ES2-MH33480B	8.0	ES2-3DA2306	Motor with brake
	162		ES2-MH33480WP	8.0	ES2-3DA2306	Motor with waterproof
	184		ES2-MH334100	10	ES2-3DA2306	
	218		ES2-MH334100B	10	ES2-3DA2306	Motor with brake
	NEMA 42	191	ES2-MH334100WP	10	ES2-3DA2306	Motor with waterproof
		162	ES2-MH342120	12	ES2-3DA2306	
		207	ES2-MH342120B	12	ES2-3DA2306	Motor with brake
		167	ES2-MH342120WP	12	ES2-3DA2306	Motor with waterproof
		244	ES2-MH342200	20	ES2-3DA2306	

Note: Contact Leadshine for Gearboxes and Encoder information.

Closed Loop Stepper Motor Specifications

NEMA 17 (42mm)



Standard Models:

Model	Length (mm)	Holding Torque(N·m)	Rated Current (A)	Inertia (Kg·cm ²)
CS-M21702	56	0.2	1.5	0.023
CS-M21704	63	0.4	1.5	0.045
CS-M21706	70	0.6	2.5	0.077
CS-M21708	83	0.8	2.5	0.11

Unit: mm 1inch=25.4mm

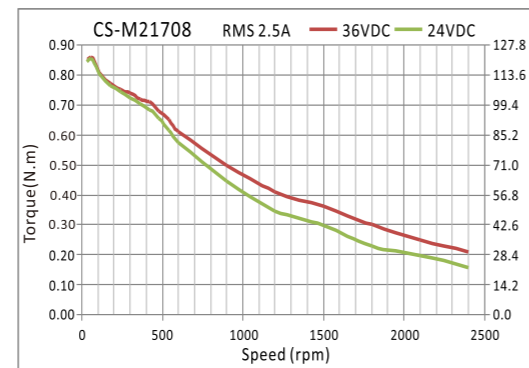
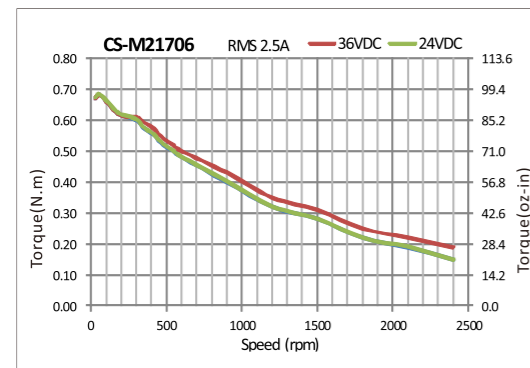
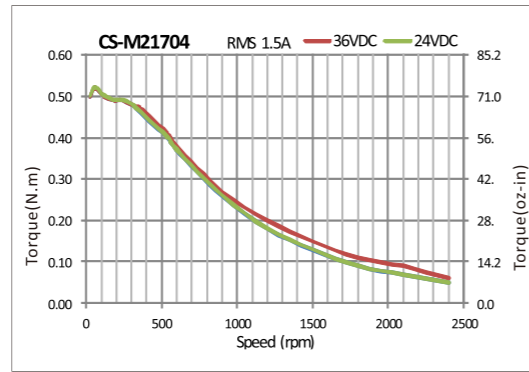
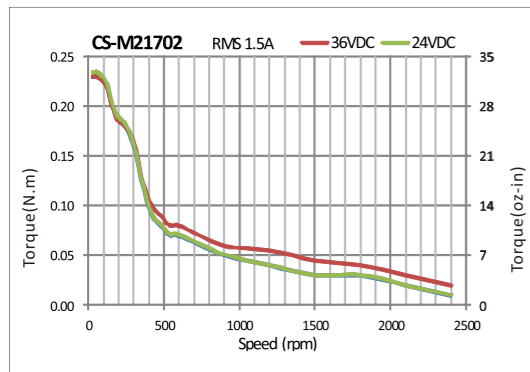
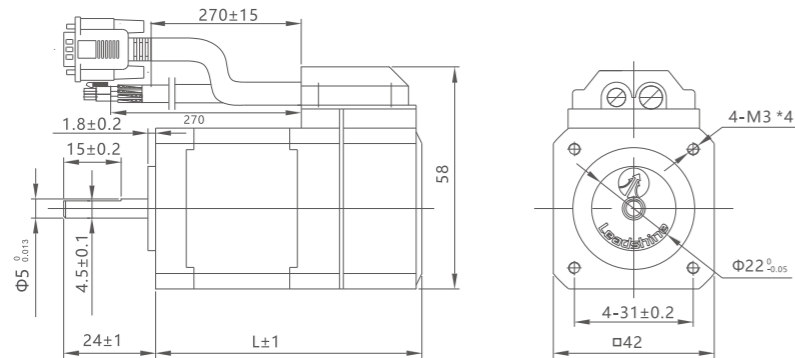

NEMA 23 (57mm)

Standard Models:



Model	Length (mm)	Holding Torque(N·m)	Rated Current (A)	Inertia (Kg·cm ²)
CS-M22306	60	0.6	3.0	0.131
CS-M22313	75	1.3	4.0	0.3
CS-M22323	95	2.3	5.0	0.48
CS-M22326	103	2.6	5.0	0.7

Note: Motors with 1/4 in(6.35mm) shaft diameter are available.

Unit: mm 1inch=25.4mm

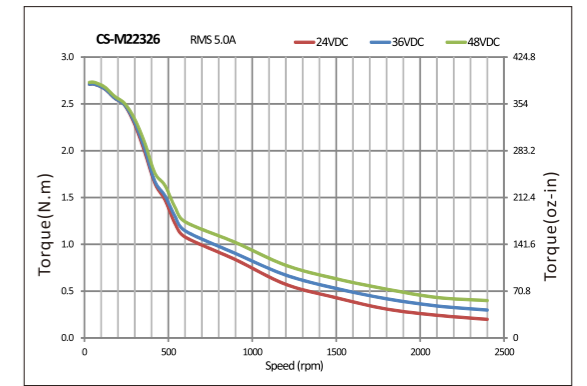
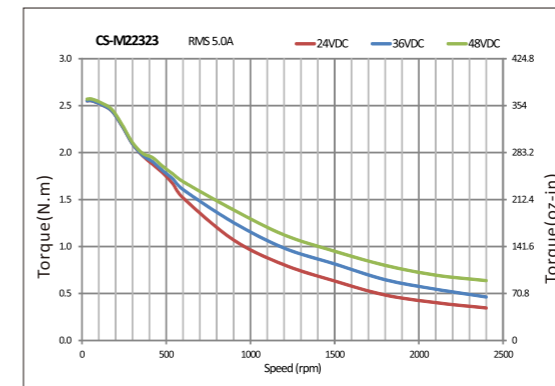
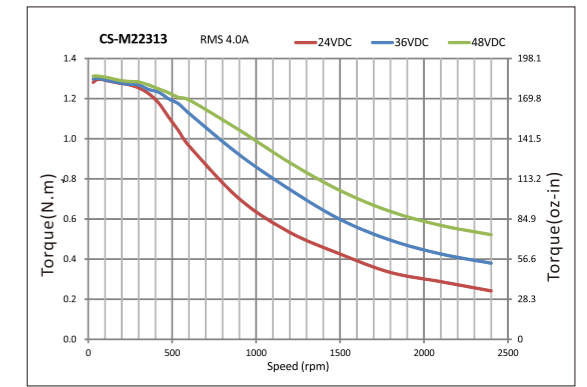
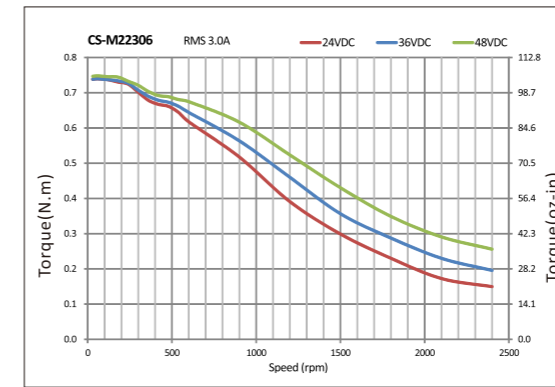
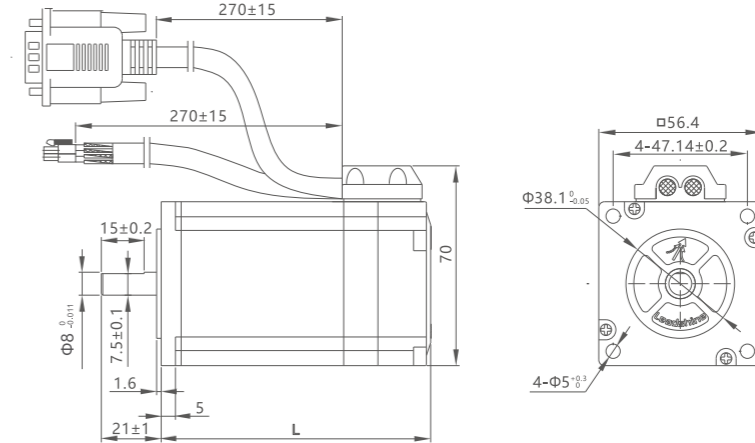

NEMA 23 (57mm)



Standard Models:

Model	Length (mm)	Holding Torque(N·m)	Rated Current (A)	Inertia (Kg·cm ²)
CS-M22321-L	86	2.1	5.0	0.49
CS-M22331-L	105	3.1	5.0	0.69

Unit: mm 1inch=25.4mm

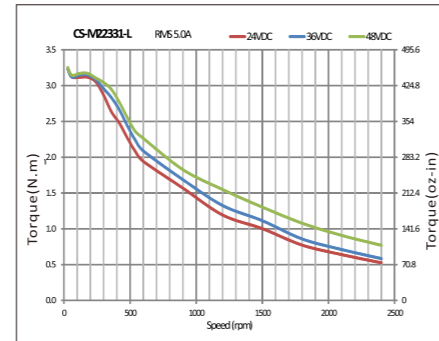
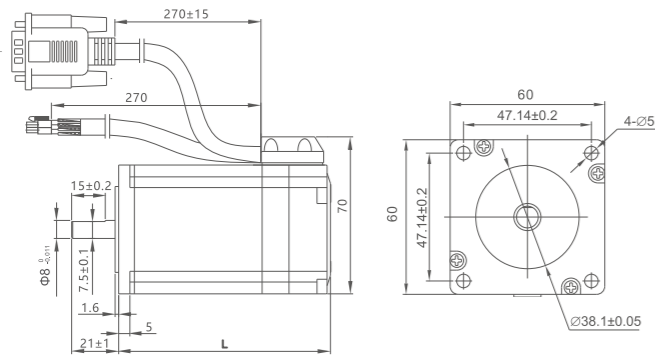

NEMA 24 (60mm)



Standard Models:

Model	Length (mm)	Holding Torque(N·m)	Rated Current (A)	Inertia (Kg·cm ²)
CS-M22422	86	2.2	5.0	0.49
CS-M22430	103	3.0	5.0	0.69

Unit: mm 1inch=25.4mm

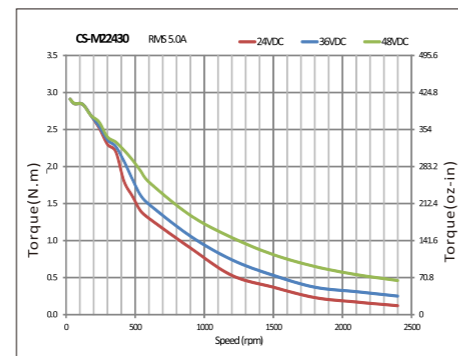
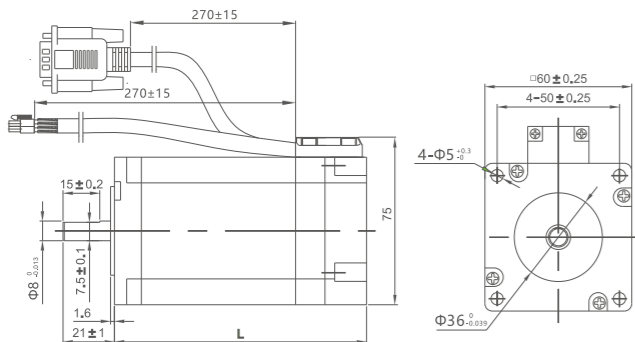

NEMA 34 (86mm)



Standard Models:

Model	Length (mm)	Holding Torque (N·m)	Rated Current (A)	Inertia (Kg·cm ²)
CS-M23435	95	3.5	4.0	1.0
CS-M23445	109	4.5	6.0	1.95
CS-M23480	127	8.0	6.0	2.5
CS-M23485	147	8.5	6.0	2.8
CS-M234120	158	12.0	6.0	3.0

Note: Motors with 1/2 in(12.7mm) shaft diameter are available.

Unit: mm 1inch=25.4mm

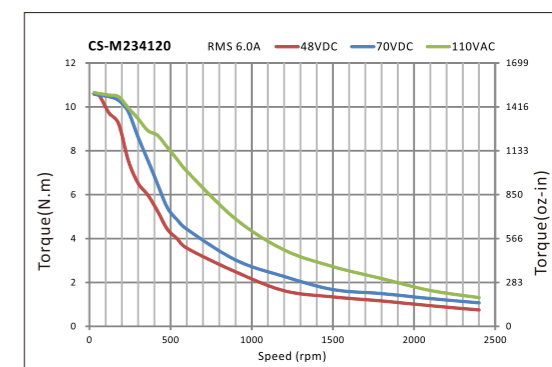
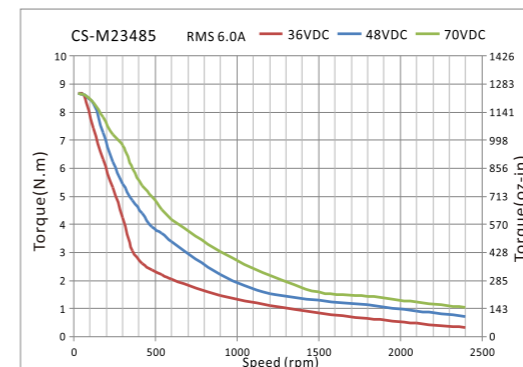
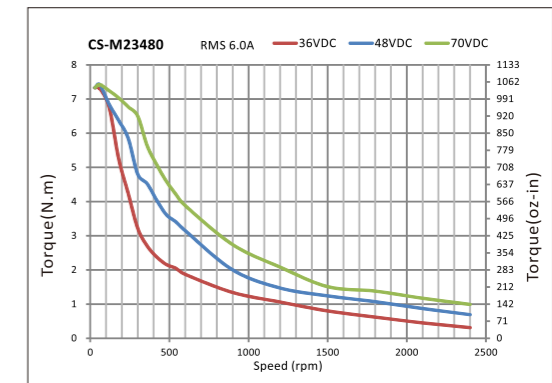
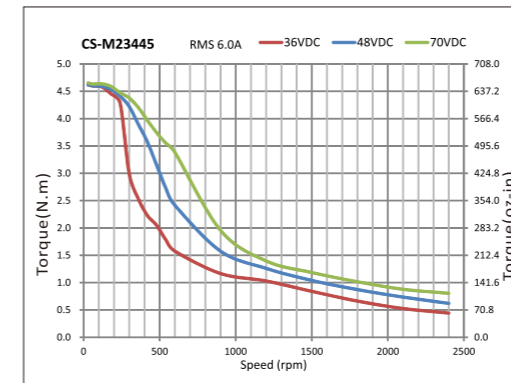
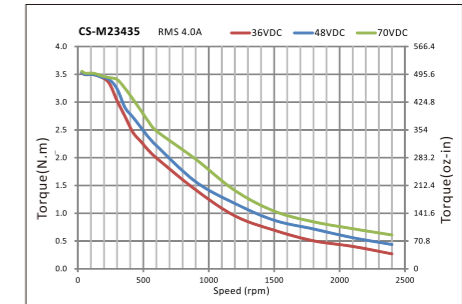
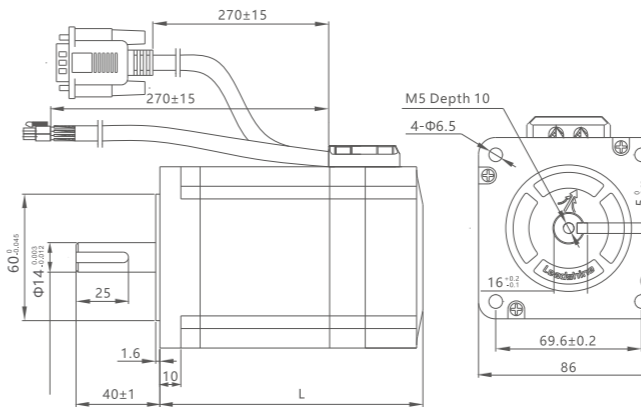

3-phase: NEMA 34, 42



Standard Models:

Model	Length (mm)	Holding Torque (N·m)	Rated Current (A)	Inertia (Kg·cm ²)
ES2-MH33480	158	8.0	6.0	3.0
ES2-MH334100	185	10.0	6.0	3.0
ES2-MH342120	162	12.0	4.2	10.8
ES2-MH342200	244	20.0	5.2	17

Unit: mm 1inch=25.4mm

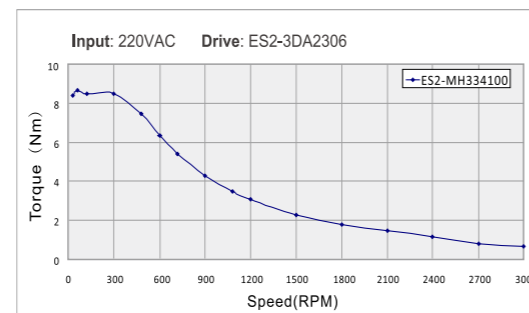
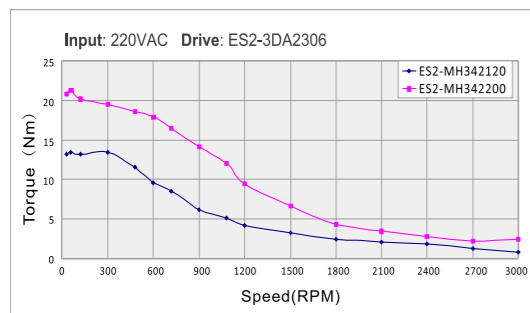
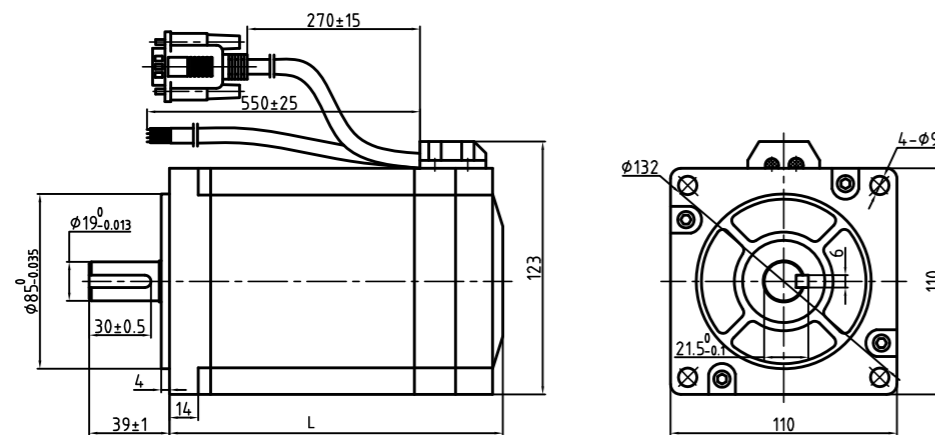
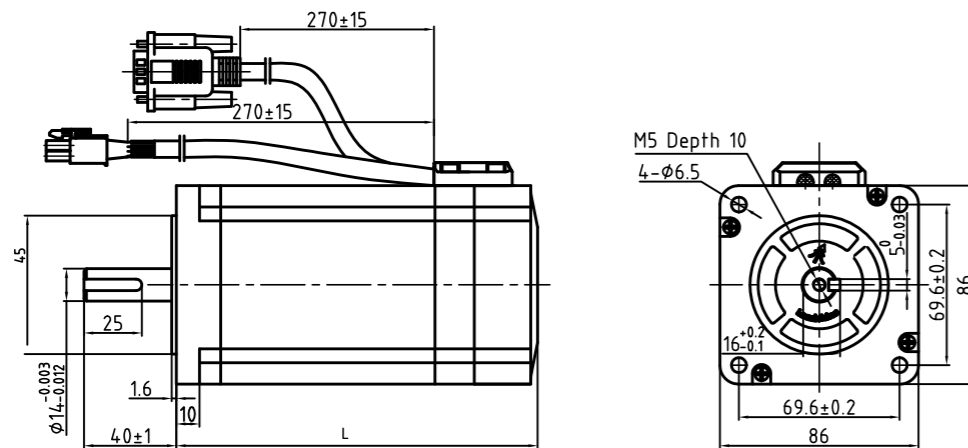

Integrated Steppers

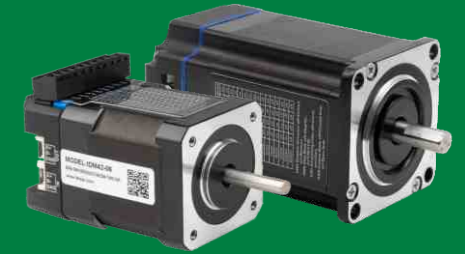

- Open Loop: iST/iEM
- Closed Loop: iES/iCS

Features

- ▶ All-In-One Solution
- ▶ Easy Setup, High Reliability
- ▶ Built-in Motion Commands
- ▶ Smooth, Quick, Accurate, Low Heating
- ▶ Compact Design
- ▶ 1000 ppr encoder optional



Specification

Model	iST/iEM	iES/iCS
Motor Type	Open Loop	Closed Loop
Holding Torque (Nm)	0.3, 0.6, 1.0, 2.0	0.6, 1.0, 2.0
Operation Modes	Step & Direction, RS485, CANopen*	
Maximum Input Frequency (kHz)	200	
Protection Functions	Over-current, Over-voltage	
Inputs	Step & Direction	Step & Direction, Enable (differential)
	RS485 / CANopen	4 digital inputs, 1 analog input (single-end)
Outputs	Step & Direction	fault out (differential)
	RS485 / CANopen	2 digital outputs (open collector)
Storage Temperature	-20 °C to 80 °C	
Ambient Temperature	0 °C to 50 °C (Heat sink)	
Humidity	40%RH to 90%RH	

Note: RS485 and CANopen Type are coming soon, please contact us tech@leadshine.com for the latest product news.

■ iEM-1706 & iCS-1706 Connector



Port	Description
DIP Switches	SW1-SW4: Microstep SW5: Motor Direction SW6: Reserved for iEM-1706 Open/Closed loop control selection for iCS-1706
Connector	PUL+/-, DIR+/-, ENA+/-, ALM+/-, GND, VCC

■ Mechanical Specifications (unit: mm, 1 inch=25.4 mm)

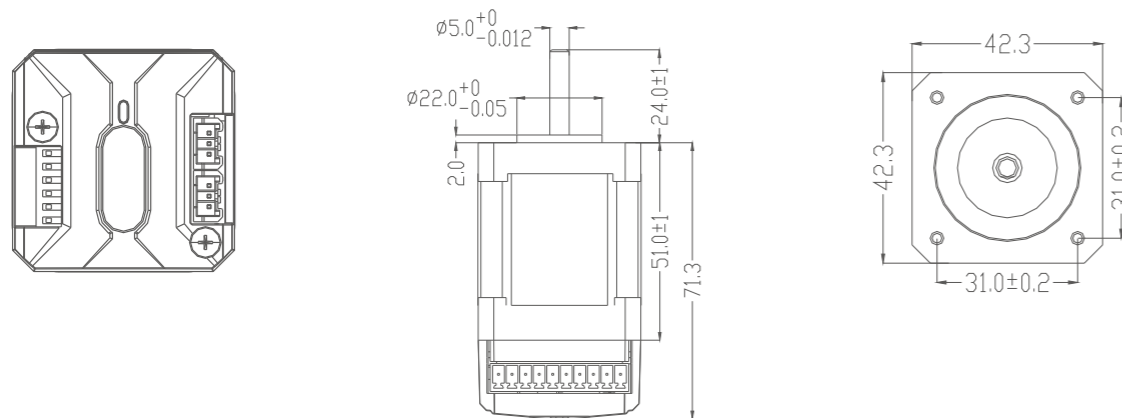

■ Tuning Cable & Software

Cable Model	CABLE-PC-ICL42
Software Name	StandardProTuner

■ iEM-2320 & iCS-2320 Connector



Port	Description
DIP Switches	SW1-SW4: Microstep SW5: Motor Direction SW6: Step&Dir and CW&CCW control pulse selection SW7: Smoothing filtering time SW8: Activated pulse edge for iEM-2320 Open/closed loop control selection for iCS-2320
Connector	PUL+/-, DIR+/-, ENA+/-, ALM+/-, In-position +/-, GND, VCC

■ Mechanical Specifications (unit: mm, 1 inch=25.4 mm)

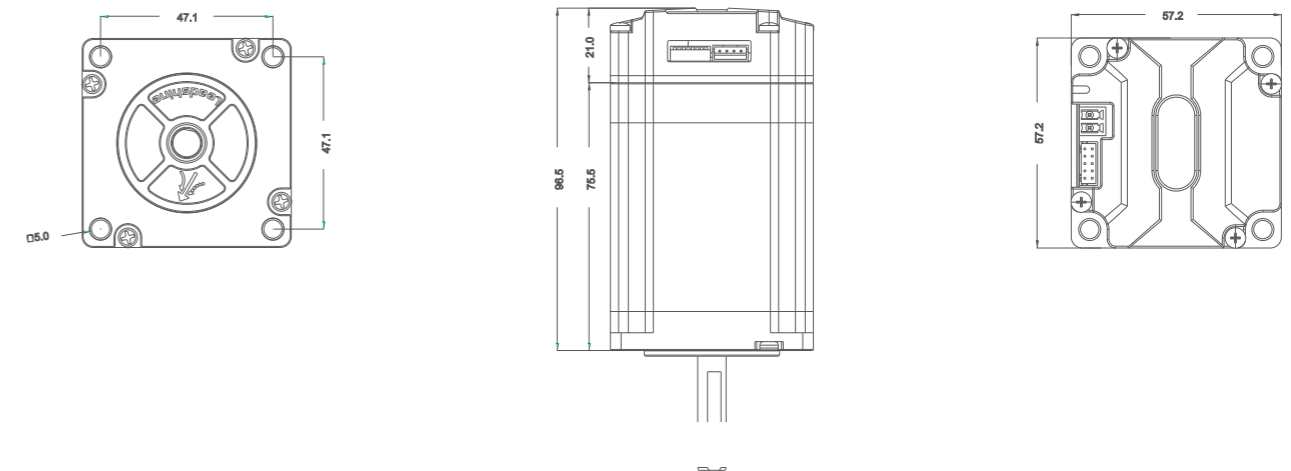

■ Tuning Cable & Software

Cable Model	CABLE-PC-1
Software Name	StandardProTuner

Other Products

- Power Supplies
- Gearboxes



LSP Series----Power Supplies

■ Features

- ▶ 1.8 times overload
- ▶ Compact Size, Light in Weight
- ▶ Use Switch to select input voltage 220VAC ± 10% or 110 VAC ± 10%
- ▶ Over-current, Over-voltage, Low-voltage Protections
- ▶ Big Power with High Efficiency
- ▶ CE and RoHS

■ Electrical Specifications

Model	Output Voltage (VDC)	Continuous Current(A)	Peak Current(A)	Input Voltage	Power (W)	Dimensions (mm)	Weight (Kg)
LSP-260-24	24	10.8	19.4	220VAC ± 10% or 110 VAC ± 10%	260	199*110*50	0.8
LSP-360-24	24	15	27		360	199*110*50	0.8
LSP-360-36	36	10	18		360	215*115*30	0.7
LSP-360-48	48	7.5	13.5		360	215*115*30	0.7
LSP-400-60	60	6.7	12		400	215*115*30	0.7

■ Mechanical Specifications

(unit: mm, 1inch=25.4mm)

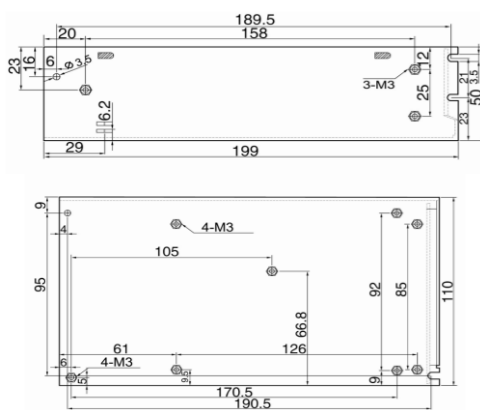

LSP-260-24, LSP-360-24

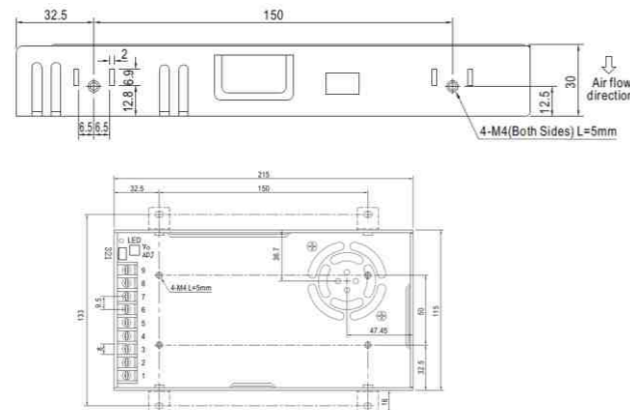

LSP-360-36, LSP-360-48, LSP-400-60

PLF Series---- Gearboxes

■ Features

- ▶ Straight tooth planetary Gearbox
- ▶ Matched NEMA 17, 23, 24, 34 stepper motors
- ▶ Gear ratio 1:3, 1:5, 1:7, 1:10 are available

■ Specifications

Size	60mm				90mm			
	3	5	7	10	3	5	7	10
Gear Ratio	3	5	7	10	3	5	7	10
Rated Output Torque (Nm)	16.5	29.5	19.5	8.5	60	94	64	40
Max Output Torque(Nm)	33.0	59.0	39.0	17.0	120	188	128	80
Rotation Inertial(Kgcm ²)	0.107	0.092	0.091	0.091	0.4	0.291	0.285	0.283
Rated Input Rotation Speed (RPM)	4000				3500			
Maximum Input Rotation Speed (RPM)	8000				6000			
Maximum Radial Force (N)	485				1020			
Maximum Axial Force (N)	380				850			
Free-load torque (N.m)	0.6				0.8			
Full-load Efficiency	96%				96%			
Backlash (arcmin)	<12				<12			
Noise (dB)	≤58				≤62			
Weight (Kg)	1.0				2.8			
Torsional Rigidity	2.3				7.5			
Average Life (h)	>20000							
Lubricant	Long-term Lubrication							
Rotation Direction	Input and output in the same direction							
Protection Class	IP65							
Installation Way	Arbitrariness							

Model	Gear Ratio	Matched Motors
PLF060-3-P2-BJ-6.35-38.1	1:3	NEMA 23 Stepper Motor with 6.35mm Shaft Diameter
PLF060-5-P2-BJ-6.35-38.1	1:5	
PLF060-7-P2-BJ-6.35-38.1	1:7	
PLF060-10-P2-BJ-6.35-38.1	1:10	
PLF060-3-P2-BJ-8-38.1	1:3	NEMA 23 Stepper Motor with 8mm Shaft Diameter
PLF060-5-P2-BJ-8-38.1	1:5	
PLF060-7-P2-BJ-8-38.1	1:7	
PLF060-10-P2-BJ-8-38.1	1:10	
PLF090-3-P2-BJ-12.7-73	1:3	NEMA 34 Stepper Motor with 12.7mm Shaft Diameter
PLF090-5-P2-BJ-12.7-73	1:5	
PLF090-7-P2-BJ-12.7-73	1:7	
PLF090-10-P2-BJ-12.7-73	1:10	
PLF090-3-P2-BJ-14-73	1:3	NEMA 34 Stepper Motor with 14mm Shaft Diameter
PLF090-5-P2-BJ-14-73	1:5	
PLF090-7-P2-BJ-14-73	1:7	
PLF090-10-P2-BJ-14-73	1:10	
PLF090-3-P2-BJ-14-60	1:3	NEMA 34 Closed Loop Stepper Motor with 14mm Shaft Diameter
PLF090-5-P2-BJ-14-60	1:5	
PLF090-7-P2-BJ-14-60	1:7	
PLF090-10-P2-BJ-14-60	1:10	
42CM08-RD05	1:5	42CM08
42CM08-RD10	1:10	
42CM06-RD05	1:5	42CM06
42CM06-RD10	1:10	
42CM06-RD20	1:20	